



US009589490B2

(12) **United States Patent**  
**Chaji et al.**

(10) **Patent No.:** **US 9,589,490 B2**  
(45) **Date of Patent:** **Mar. 7, 2017**

(54) **SYSTEM AND METHODS FOR EXTRACTION OF THRESHOLD AND MOBILITY PARAMETERS IN AMOLED DISPLAYS**

(71) Applicant: **Ignis Innovation Inc.**, Waterloo (CA)

(72) Inventors: **Gholamreza Chaji**, Waterloo (CA);  
**Yaser Azizi**, Waterloo (CA)

(73) Assignee: **Ignis Innovation Inc.**, Waterloo (CA)

(\*) Notice: Subject to any disclaimer, the term of this patent is extended or adjusted under 35 U.S.C. 154(b) by 0 days.

(21) Appl. No.: **15/154,445**

(22) Filed: **May 13, 2016**

(65) **Prior Publication Data**

US 2016/0253937 A1 Sep. 1, 2016

**Related U.S. Application Data**

(63) Continuation of application No. 14/680,554, filed on Apr. 7, 2015, now Pat. No. 9,355,584, which is a (Continued)

(51) **Int. Cl.**  
**G09G 3/00** (2006.01)  
**G09G 3/32** (2016.01)  
**G01R 19/00** (2006.01)

(52) **U.S. Cl.**  
CPC ..... **G09G 3/006** (2013.01); **G01R 19/0092** (2013.01); **G09G 3/3233** (2013.01); (Continued)

(58) **Field of Classification Search**  
None  
See application file for complete search history.

(56) **References Cited**

**U.S. PATENT DOCUMENTS**

3,506,851 A 4/1970 Polkinghorn  
3,774,055 A 11/1973 Bapat  
(Continued)

**FOREIGN PATENT DOCUMENTS**

CA 1 294 034 1/1992  
CA 2 109 951 11/1992  
(Continued)

**OTHER PUBLICATIONS**

Ahnood : "Effect of threshold voltage instability on field effect mobility in thin film transistors deduced from constant current measurements"; dated Aug. 2009.

(Continued)

*Primary Examiner* — Nicholas Lee

(74) *Attorney, Agent, or Firm* — Nixon Peabody LLP

(57) **ABSTRACT**

A system to improve the extraction of transistor and OLED parameters in an AMOLED display includes a pixel circuit having an organic light emitting device, a drive device to provide a programmable drive current to the light emitting device, a programming input to provide the programming signal, and a storage device to store the programming signal. A charge-pump amplifier has a current input and a voltage output. The charge-pump amplifier includes an operational amplifier in negative feedback configuration. The feedback is provided by a capacitor connected between the output and the inverting input of the operational amplifier. A common-mode voltage source drives the non-inverting input of the operational amplifier. An electronic switch is coupled across the capacitor to reset the capacitor. A switch module including the input is coupled to the output of the pixel circuit and an output is coupled to the input of the charge-pump amplifier.

**4 Claims, 12 Drawing Sheets**

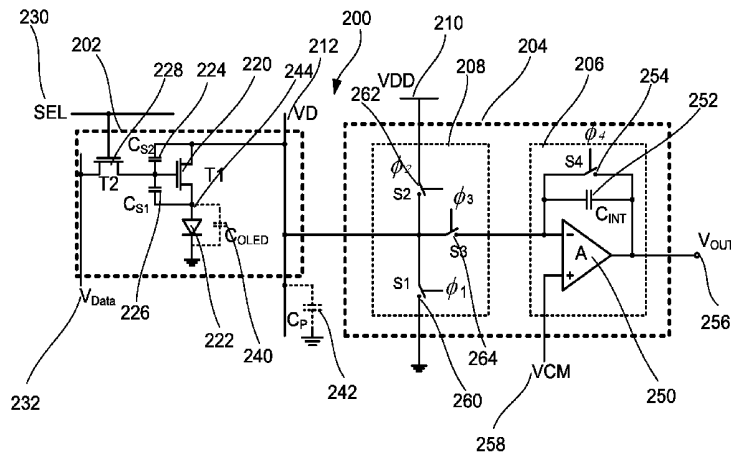

**Related U.S. Application Data**

continuation of application No. 13/950,795, filed on Jul. 25, 2013, now Pat. No. 9,093,029, which is a continuation of application No. 13/112,468, filed on May 20, 2011, now Pat. No. 8,576,217.

(52) **U.S. Cl.**

CPC ..... *G09G 3/3258* (2013.01); *G09G 3/3291* (2013.01); *G09G 2300/043* (2013.01); *G09G 2300/0819* (2013.01); *G09G 2300/0842* (2013.01); *G09G 2300/0866* (2013.01); *G09G 2310/0251* (2013.01); *G09G 2320/029* (2013.01); *G09G 2320/0233* (2013.01); *G09G 2320/0295* (2013.01); *G09G 2320/043* (2013.01); *G09G 2320/045* (2013.01); *G09G 2330/028* (2013.01)

6,320,325	B1	11/2001	Cok
6,323,631	B1	11/2001	Juang
6,329,971	B2	12/2001	McKnight
6,356,029	B1	3/2002	Hunter
6,373,454	B1	4/2002	Knapp
6,392,617	B1	5/2002	Gleason
6,404,139	B1	6/2002	Sasaki
6,414,661	B1	7/2002	Shen
6,417,825	B1	7/2002	Stewart
6,433,488	B1	8/2002	Bu
6,437,106	B1	8/2002	Stoner
6,445,369	B1	9/2002	Yang
6,475,845	B2	11/2002	Kimura
6,501,098	B2	12/2002	Yamazaki
6,501,466	B1	12/2002	Yamagishi
6,518,962	B2	2/2003	Kimura
6,522,315	B2	2/2003	Ozawa
6,525,683	B1	2/2003	Gu
6,531,827	B2	3/2003	Kawashima
6,542,138	B1	4/2003	Shannon
6,555,420	B1	4/2003	Yamazaki
6,577,302	B2	6/2003	Hunter
6,580,408	B1	6/2003	Bae
6,580,657	B2	6/2003	Sanford
6,583,398	B2	6/2003	Harkin
6,583,775	B1	6/2003	Sekiya
6,594,606	B2	7/2003	Everitt
6,618,030	B2	9/2003	Kane
6,639,244	B1	10/2003	Yamazaki
6,668,645	B1	12/2003	Gilmour
6,677,713	B1	1/2004	Sung
6,680,580	B1	1/2004	Sung
6,687,266	B1	2/2004	Ma
6,690,000	B1	2/2004	Muramatsu
6,690,344	B1	2/2004	Takeuchi
6,693,388	B2	2/2004	Oomura
6,693,610	B2	2/2004	Shannon
6,697,057	B2	2/2004	Koyama
6,720,942	B2	4/2004	Lee
6,724,151	B2	4/2004	Yoo
6,734,636	B2	5/2004	Sanford
6,738,034	B2	5/2004	Kaneko
6,738,035	B1	5/2004	Fan
6,753,655	B2	6/2004	Shih
6,753,834	B2	6/2004	Mikami
6,756,741	B2	6/2004	Li
6,756,952	B1	6/2004	Decaux
6,756,958	B2	6/2004	Furuhashi
6,771,028	B1	8/2004	Winters
6,777,712	B2	8/2004	Sanford
6,777,888	B2	8/2004	Kondo
6,781,567	B2	8/2004	Kimura
6,806,497	B2	10/2004	Jo
6,806,638	B2	10/2004	Lih et al.
6,806,857	B2	10/2004	Sempel
6,809,706	B2	10/2004	Shimoda
6,815,975	B2	11/2004	Nara
6,828,950	B2	12/2004	Koyama
6,853,371	B2	2/2005	Miyajima
6,859,193	B1	2/2005	Yumoto
6,873,117	B2	3/2005	Ishizuka
6,876,346	B2	4/2005	Anzai
6,885,356	B2	4/2005	Hashimoto
6,900,485	B2	5/2005	Lee
6,903,734	B2	6/2005	Eu
6,909,243	B2	6/2005	Inukai
6,909,419	B2	6/2005	Zavracky
6,911,960	B1	6/2005	Yokoyama
6,911,964	B2	6/2005	Lee
6,914,448	B2	7/2005	Jinno
6,919,871	B2	7/2005	Kwon
6,924,602	B2	8/2005	Komiya
6,937,215	B2	8/2005	Lo
6,937,220	B2	8/2005	Kitaura
6,940,214	B1	9/2005	Komiya
6,943,500	B2	9/2005	LeChevalier
6,947,022	B2	9/2005	McCartney
6,954,194	B2	10/2005	Matsumoto
6,956,547	B2	10/2005	Bae

(56)

**References Cited**

U.S. PATENT DOCUMENTS

4,090,096	A	5/1978	Nagami
4,160,934	A	7/1979	Kirsch
4,354,162	A	10/1982	Wright
4,943,956	A	7/1990	Noro
4,996,523	A	2/1991	Bell
5,153,420	A	10/1992	Hack
5,198,803	A	3/1993	Shie
5,204,661	A	4/1993	Hack
5,266,515	A	11/1993	Robb
5,489,918	A	2/1996	Mosier
5,498,880	A	3/1996	Lee
5,557,342	A	9/1996	Eto
5,572,444	A	11/1996	Lentz
5,589,847	A	12/1996	Lewis
5,619,033	A	4/1997	Weisfield
5,648,276	A	7/1997	Hara
5,670,973	A	9/1997	Bassetti
5,684,365	A	11/1997	Tang
5,691,783	A	11/1997	Numao
5,714,968	A	2/1998	Ikeda
5,723,950	A	3/1998	Wei
5,744,824	A	4/1998	Kousai
5,745,660	A	4/1998	Kolpatzik
5,748,160	A	5/1998	Shieh
5,815,303	A	9/1998	Berlin
5,870,071	A	2/1999	Kawahata
5,874,803	A	2/1999	Garbuzov
5,880,582	A	3/1999	Sawada
5,903,248	A	5/1999	Irwin
5,917,280	A	6/1999	Burrows
5,923,794	A	7/1999	McGrath
5,945,972	A	8/1999	Okumura
5,949,398	A	9/1999	Kim
5,952,789	A	9/1999	Stewart
5,952,991	A	9/1999	Akiyama
5,982,104	A	11/1999	Sasaki
5,990,629	A	11/1999	Yamada
6,023,259	A	2/2000	Howard
6,069,365	A	5/2000	Chow
6,091,203	A	7/2000	Kawashima
6,097,360	A	8/2000	Holloman
6,144,222	A	11/2000	Ho
6,177,915	B1	1/2001	Beeteson
6,229,506	B1	5/2001	Dawson
6,229,508	B1	5/2001	Kane
6,246,180	B1	6/2001	Nishigaki
6,252,248	B1	6/2001	Sano
6,259,424	B1	7/2001	Kurogane
6,262,589	B1	7/2001	Tamukai
6,271,825	B1	8/2001	Greene
6,288,696	B1	9/2001	Holloman
6,304,039	B1	10/2001	Appelberg
6,307,322	B1	10/2001	Dawson
6,310,962	B1	10/2001	Chung

(56)

## References Cited

## U.S. PATENT DOCUMENTS

			8,232,939 B2	7/2012	Nathan
			8,259,044 B2	9/2012	Nathan
			8,264,431 B2	9/2012	Bulovic
			8,279,143 B2	10/2012	Nathan
6,975,142 B2	12/2005	Azami	8,339,386 B2	12/2012	Leon
6,975,332 B2	12/2005	Arnold	8,441,206 B2	5/2013	Myers
6,995,510 B2	2/2006	Murakami	8,493,296 B2	7/2013	Ogawa
6,995,519 B2	2/2006	Arnold	2001/0002703 A1	6/2001	Koyama
7,023,408 B2	4/2006	Chen	2001/0009283 A1	7/2001	Arao
7,027,015 B2	4/2006	Booth, Jr.	2001/0024181 A1	9/2001	Kubota
7,027,078 B2	4/2006	Reihl	2001/0024186 A1	9/2001	Kane
7,034,793 B2	4/2006	Sekiya	2001/0026257 A1	10/2001	Kimura
7,038,392 B2	5/2006	Libsch	2001/0030323 A1	10/2001	Ikeda
7,057,359 B2	6/2006	Hung	2001/0035863 A1	11/2001	Kimura
7,061,451 B2	6/2006	Kimura	2001/0038367 A1	11/2001	Inukai
7,064,733 B2	6/2006	Cok	2001/0040541 A1	11/2001	Yoneda
7,071,932 B2	7/2006	Libsch	2001/0043173 A1	11/2001	Troutman
7,088,051 B1	8/2006	Cok	2001/0045929 A1	11/2001	Prache
7,088,052 B2	8/2006	Kimura	2001/0052606 A1	12/2001	Sempel
7,102,378 B2	9/2006	Kuo	2001/0052940 A1	12/2001	Hagihara
7,106,285 B2	9/2006	Naugler	2002/0000576 A1	1/2002	Inukai
7,112,820 B2	9/2006	Change	2002/0011796 A1	1/2002	Koyama
7,116,058 B2	10/2006	Lo	2002/0011799 A1	1/2002	Kimura
7,119,493 B2	10/2006	Fryer	2002/0012057 A1	1/2002	Kimura
7,122,835 B1	10/2006	Ikeda	2002/0014851 A1	2/2002	Tai
7,127,380 B1	10/2006	Iverson	2002/0018034 A1	2/2002	Ohki
7,129,914 B2	10/2006	Knapp	2002/0030190 A1	3/2002	Ohtani
7,161,566 B2	1/2007	Cok	2002/0047565 A1	4/2002	Nara
7,164,417 B2	1/2007	Cok	2002/0052086 A1	5/2002	Maeda
7,193,589 B2	3/2007	Yoshida	2002/0067134 A1	6/2002	Kawashima
7,224,332 B2	5/2007	Cok	2002/0084463 A1	7/2002	Sanford
7,227,519 B1	6/2007	Kawase	2002/0101152 A1	8/2002	Kimura
7,245,277 B2	7/2007	Ishizuka	2002/0101172 A1	8/2002	Bu
7,248,236 B2	7/2007	Nathan	2002/0105279 A1	8/2002	Kimura
7,262,753 B2	8/2007	Tanghe	2002/0117722 A1	8/2002	Osada
7,274,363 B2	9/2007	Ishizuka	2002/0122308 A1	9/2002	Ikeda
7,310,092 B2	12/2007	Imamura	2002/0158587 A1	10/2002	Komiya
7,315,295 B2	1/2008	Kimura	2002/0158666 A1	10/2002	Azami
7,321,348 B2	1/2008	Cok	2002/0158823 A1	10/2002	Zavracky
7,339,560 B2	3/2008	Sun	2002/0167471 A1	11/2002	Everitt
7,355,574 B1	4/2008	Leon	2002/0167474 A1	11/2002	Everitt
7,358,941 B2	4/2008	Ono	2002/0180369 A1	12/2002	Koyama
7,368,868 B2	5/2008	Sakamoto	2002/0180721 A1	12/2002	Kimura
7,397,485 B2	7/2008	Miller	2002/0181276 A1	12/2002	Yamazaki
7,411,571 B2	8/2008	Huh	2002/0186214 A1	12/2002	Siwinski
7,414,600 B2	8/2008	Nathan	2002/0190924 A1	12/2002	Asano
7,423,617 B2	9/2008	Giraldo	2002/0190971 A1	12/2002	Nakamura
7,453,054 B2	11/2008	Lee	2002/0195967 A1	12/2002	Kim
7,474,285 B2	1/2009	Kimura	2002/0195968 A1	12/2002	Sanford
7,502,000 B2	3/2009	Yuki	2003/0020413 A1	1/2003	Oomura
7,528,812 B2	5/2009	Tsuge	2003/0030603 A1	2/2003	Shimoda
7,535,449 B2	5/2009	Miyazawa	2003/0043088 A1	3/2003	Booth
7,554,512 B2	6/2009	Steer	2003/0057895 A1	3/2003	Kimura
7,569,849 B2	8/2009	Nathan	2003/0058226 A1	3/2003	Bertram
7,576,718 B2	8/2009	Miyazawa	2003/0062524 A1	4/2003	Kimura
7,580,012 B2	8/2009	Kim	2003/0063081 A1	4/2003	Kimura
7,589,707 B2	9/2009	Chou	2003/0071821 A1	4/2003	Sundahl
7,609,239 B2	10/2009	Chang	2003/0076048 A1	4/2003	Rutherford
7,619,594 B2	11/2009	Hu	2003/0090447 A1	5/2003	Kimura
7,619,597 B2	11/2009	Nathan	2003/0090481 A1	5/2003	Kimura
7,633,470 B2	12/2009	Kane	2003/0107560 A1	6/2003	Yumoto
7,656,370 B2	2/2010	Schneider	2003/0111966 A1	6/2003	Mikami
7,675,485 B2	3/2010	Steer	2003/0122745 A1	7/2003	Miyazawa
7,800,558 B2	9/2010	Routley	2003/0122813 A1	7/2003	Ishizuki
7,847,764 B2	12/2010	Cok	2003/0142088 A1	7/2003	LeChevalier
7,859,492 B2	12/2010	Kohno	2003/0151569 A1	8/2003	Lee
7,868,859 B2	1/2011	Tomida	2003/0156101 A1	8/2003	Le Chevalier
7,876,294 B2	1/2011	Sasaki	2003/0169241 A1	9/2003	LeChevalier
7,924,249 B2	4/2011	Nathan	2003/0174152 A1	9/2003	Noguchi
7,932,883 B2	4/2011	Klompenshouwer	2003/0179626 A1	9/2003	Sanford
7,969,390 B2	6/2011	Yoshida	2003/0185438 A1	10/2003	Osawa
7,978,187 B2	7/2011	Nathan	2003/0197663 A1	10/2003	Lee
7,994,712 B2	8/2011	Sung	2003/0210256 A1	11/2003	Mori
8,026,876 B2	9/2011	Nathan	2003/0230141 A1	12/2003	Gilmour
8,049,420 B2	11/2011	Tamura	2003/0230980 A1	12/2003	Forrest
8,077,123 B2	12/2011	Naugler, Jr.	2003/0231148 A1	12/2003	Lin
8,115,707 B2	2/2012	Nathan	2004/0032382 A1	2/2004	Cok
8,208,084 B2	6/2012	Lin	2004/0041750 A1	3/2004	Abe
8,223,177 B2	7/2012	Nathan	2004/0066357 A1	4/2004	Kawasaki

(56)

## References Cited

## U.S. PATENT DOCUMENTS

2004/0070557	A1	4/2004	Asano	2006/0007249	A1	1/2006	Reddy
2004/0070565	A1	4/2004	Nayar	2006/0012310	A1	1/2006	Chen
2004/0090186	A1	5/2004	Kanauchi	2006/0012311	A1	1/2006	Ogawa
2004/0090400	A1	5/2004	Yoo	2006/0015272	A1	1/2006	Giraldo et al.
2004/0095297	A1	5/2004	Libsch	2006/0022305	A1	2/2006	Yamashita
2004/0100427	A1	5/2004	Miyazawa	2006/0027807	A1	2/2006	Nathan
2004/0108518	A1	6/2004	Jo	2006/0030084	A1	2/2006	Young
2004/0135749	A1	7/2004	Kondakov	2006/0038758	A1	2/2006	Routley
2004/0140982	A1	7/2004	Pate	2006/0038762	A1	2/2006	Chou
2004/0145547	A1	7/2004	Oh	2006/0044227	A1	3/2006	Hadcock
2004/0150592	A1	8/2004	Mizukoshi	2006/0061248	A1	3/2006	Cok
2004/0150594	A1	8/2004	Koyama	2006/0066533	A1	3/2006	Sato
2004/0150595	A1	8/2004	Kasai	2006/0077134	A1	4/2006	Hector et al.
2004/0155841	A1	8/2004	Kasai	2006/0077135	A1	4/2006	Cok
2004/0174347	A1	9/2004	Sun	2006/0077142	A1	4/2006	Kwon
2004/0174349	A1	9/2004	Libsch	2006/0082523	A1	4/2006	Guo
2004/0174354	A1	9/2004	Ono	2006/0092185	A1	5/2006	Jo
2004/0178743	A1	9/2004	Miller	2006/0097628	A1	5/2006	Suh
2004/0183759	A1	9/2004	Stevenson	2006/0097631	A1	5/2006	Lee
2004/0196275	A1	10/2004	Hattori	2006/0103611	A1	5/2006	Choi
2004/0207615	A1	10/2004	Yumoto	2006/0125740	A1	6/2006	Shirasaki et al.
2004/0227697	A1	11/2004	Mori	2006/0149493	A1	7/2006	Sambandan
2004/0233125	A1	11/2004	Tanghe	2006/0170623	A1	8/2006	Naugler, Jr.
2004/0239596	A1	12/2004	Ono	2006/0176250	A1	8/2006	Nathan
2004/0252089	A1	12/2004	Ono	2006/0208961	A1	9/2006	Nathan
2004/0257313	A1	12/2004	Kawashima	2006/0208971	A1	9/2006	Deane
2004/0257353	A1	12/2004	Imamura	2006/0214888	A1	9/2006	Schneider
2004/0257355	A1	12/2004	Naugler	2006/0231740	A1	10/2006	Kasai
2004/0263437	A1	12/2004	Hattori	2006/0232522	A1	10/2006	Roy
2004/0263444	A1	12/2004	Kimura	2006/0244697	A1	11/2006	Lee
2004/0263445	A1	12/2004	Inukai	2006/0256048	A1	11/2006	Fish et al.
2004/0263541	A1	12/2004	Takeuchi	2006/0261841	A1	11/2006	Fish
2005/0007355	A1	1/2005	Miura	2006/0273997	A1	12/2006	Nathan
2005/0007357	A1	1/2005	Yamashita	2006/0279481	A1	12/2006	Haruna
2005/0007392	A1	1/2005	Kasai	2006/0284801	A1	12/2006	Yoon
2005/0017650	A1	1/2005	Fryer	2006/0284802	A1	12/2006	Kohno
2005/0024081	A1	2/2005	Kuo	2006/0284895	A1	12/2006	Marcu
2005/0024393	A1	2/2005	Kondo	2006/0290614	A1	12/2006	Nathan
2005/0030267	A1	2/2005	Tanghe	2006/0290618	A1	12/2006	Goto
2005/0057484	A1	3/2005	Diefenbaugh	2007/0001937	A1	1/2007	Park
2005/0057580	A1	3/2005	Yamano	2007/0001939	A1	1/2007	Hashimoto
2005/0067970	A1	3/2005	Libsch	2007/0008251	A1	1/2007	Kohno
2005/0067971	A1	3/2005	Kane	2007/0008268	A1	1/2007	Park
2005/0068270	A1	3/2005	Awakura	2007/0008297	A1	1/2007	Bassetti
2005/0068275	A1	3/2005	Kane	2007/0057873	A1	3/2007	Uchino
2005/0073264	A1	4/2005	Matsumoto	2007/0057874	A1	3/2007	Le Roy
2005/0083323	A1	4/2005	Suzuki	2007/0069998	A1	3/2007	Naugler
2005/0088103	A1	4/2005	Kageyama	2007/0075727	A1	4/2007	Nakano
2005/0110420	A1	5/2005	Arnold	2007/0076226	A1	4/2007	Klompenuwer
2005/0110807	A1	5/2005	Chang	2007/0080905	A1	4/2007	Takahara
2005/0122294	A1	6/2005	Ben-David	2007/0080906	A1	4/2007	Tanabe
2005/0140598	A1	6/2005	Kim	2007/0080908	A1	4/2007	Nathan
2005/0140610	A1	6/2005	Smith	2007/0097038	A1	5/2007	Yamazaki
2005/0145891	A1	7/2005	Abe	2007/0097041	A1	5/2007	Park
2005/0156831	A1	7/2005	Yamazaki	2007/0103411	A1	5/2007	Cok et al.
2005/0162079	A1	7/2005	Sakamoto	2007/0103419	A1	5/2007	Uchino
2005/0168416	A1	8/2005	Hashimoto	2007/0115221	A1	5/2007	Buchhauser
2005/0179626	A1	8/2005	Yuki	2007/0126672	A1	6/2007	Tada et al.
2005/0179628	A1	8/2005	Kimura	2007/0164664	A1	7/2007	Ludwicki
2005/0185200	A1	8/2005	Tobol	2007/0164938	A1	7/2007	Shin
2005/0200575	A1	9/2005	Kim	2007/0182671	A1	8/2007	Nathan
2005/0206590	A1	9/2005	Sasaki	2007/0236134	A1	10/2007	Ho
2005/0212787	A1	9/2005	Noguchi	2007/0236440	A1	10/2007	Wacyk
2005/0219184	A1	10/2005	Zehner	2007/0236517	A1	10/2007	Kimpe
2005/0225683	A1	10/2005	Nozawa	2007/0241999	A1	10/2007	Lin
2005/0248515	A1	11/2005	Naugler	2007/0273294	A1	11/2007	Nagayama
2005/0269959	A1	12/2005	Uchino	2007/0285359	A1	12/2007	Ono
2005/0269960	A1	12/2005	Ono	2007/0290957	A1	12/2007	Cok
2005/0280615	A1	12/2005	Cok	2007/0290958	A1	12/2007	Cok
2005/0280766	A1	12/2005	Johnson	2007/0296672	A1	12/2007	Kim
2005/0285822	A1	12/2005	Reddy	2008/0001525	A1	1/2008	Chao
2005/0285825	A1	12/2005	Eom	2008/0001544	A1	1/2008	Murakami
2006/0001613	A1	1/2006	Routley	2008/0030518	A1	2/2008	Higgins
2006/0007072	A1	1/2006	Choi	2008/0036706	A1	2/2008	Kitazawa
2006/0007206	A1	1/2006	Reddy et al.	2008/0036708	A1	2/2008	Shirasaki
				2008/0042942	A1	2/2008	Takahashi
				2008/0042948	A1	2/2008	Yamashita
				2008/0048951	A1	2/2008	Naugler, Jr.
				2008/0055209	A1	3/2008	Cok

(56)

## References Cited

## U.S. PATENT DOCUMENTS

2008/0055211 A1 3/2008 Ogawa  
 2008/0074413 A1 3/2008 Ogura  
 2008/0088549 A1 4/2008 Nathan  
 2008/0088648 A1 4/2008 Nathan  
 2008/0111766 A1 5/2008 Uchino  
 2008/0116787 A1 5/2008 Hsu  
 2008/0117144 A1 5/2008 Nakano et al.  
 2008/0136770 A1 6/2008 Peker et al.  
 2008/0150845 A1 6/2008 Ishii  
 2008/0150847 A1 6/2008 Kim  
 2008/0158115 A1 7/2008 Cordes  
 2008/0158648 A1 7/2008 Cummings  
 2008/0191976 A1 8/2008 Nathan  
 2008/0198103 A1 8/2008 Toyomura  
 2008/0211749 A1 9/2008 Weitbruch  
 2008/0218451 A1 9/2008 Miyamoto  
 2008/0231558 A1 9/2008 Naugler  
 2008/0231562 A1 9/2008 Kwon  
 2008/0231625 A1 9/2008 Minami  
 2008/0246713 A1 10/2008 Lee  
 2008/0252223 A1 10/2008 Toyoda  
 2008/0252571 A1 10/2008 Hente  
 2008/0259020 A1 10/2008 Fisekovic  
 2008/0290805 A1 11/2008 Yamada  
 2008/0297055 A1 12/2008 Miyake  
 2009/0033598 A1 2/2009 Suh  
 2009/0058772 A1 3/2009 Lee  
 2009/0109142 A1 4/2009 Takahara  
 2009/0121994 A1 5/2009 Miyata  
 2009/0146926 A1 6/2009 Sung  
 2009/0160743 A1 6/2009 Tomida  
 2009/0174628 A1 7/2009 Wang  
 2009/0184901 A1 7/2009 Kwon  
 2009/0195483 A1 8/2009 Naugler, Jr.  
 2009/0201281 A1 8/2009 Routley  
 2009/0206764 A1 8/2009 Schemmann  
 2009/0207160 A1 8/2009 Shirasaki et al.  
 2009/0213046 A1 8/2009 Nam  
 2009/0244046 A1 10/2009 Seto  
 2009/0262047 A1 10/2009 Yamashita  
 2010/0004891 A1 1/2010 Ahlers  
 2010/0026725 A1 2/2010 Smith  
 2010/0039422 A1 2/2010 Seto  
 2010/0039458 A1 2/2010 Nathan  
 2010/0045646 A1 2/2010 Kishi  
 2010/0045650 A1 2/2010 Fish et al.  
 2010/0060911 A1 3/2010 Marcu  
 2010/0079419 A1 4/2010 Shibusawa  
 2010/0085282 A1 4/2010 Yu  
 2010/0103160 A1 4/2010 Jeon  
 2010/0134469 A1 6/2010 Ogura et al.  
 2010/0134475 A1 6/2010 Ogura et al.  
 2010/0165002 A1 7/2010 Ahn  
 2010/0194670 A1 8/2010 Cok  
 2010/0207960 A1 8/2010 Kimpe  
 2010/0225630 A1 9/2010 Levey  
 2010/0251295 A1 9/2010 Amento  
 2010/0277400 A1 11/2010 Jeong  
 2010/0315319 A1 12/2010 Cok  
 2011/0050870 A1 3/2011 Hanari  
 2011/0063197 A1 3/2011 Chung  
 2011/0069051 A1 3/2011 Nakamura  
 2011/0069089 A1 3/2011 Kopf  
 2011/0069096 A1 3/2011 Li  
 2011/0074750 A1 3/2011 Leon  
 2011/0074762 A1 3/2011 Shirasaki et al.  
 2011/0149166 A1 6/2011 Botzas  
 2011/0169798 A1 7/2011 Lee  
 2011/0175895 A1 7/2011 Hayakawa  
 2011/0181630 A1 7/2011 Smith  
 2011/0199395 A1 8/2011 Nathan  
 2011/0227964 A1 9/2011 Chaji  
 2011/0242074 A1 10/2011 Bert et al.

2011/0273399 A1 11/2011 Lee  
 2011/0292006 A1 12/2011 Kim  
 2011/0293480 A1 12/2011 Mueller  
 2012/0056558 A1 3/2012 Toshiya  
 2012/0062565 A1 3/2012 Fuchs  
 2012/0262184 A1 10/2012 Shen  
 2012/0299970 A1 11/2012 Bae  
 2012/0299978 A1 11/2012 Chaji  
 2013/0027381 A1 1/2013 Nathan  
 2013/0057595 A1 3/2013 Nathan  
 2013/0112960 A1 5/2013 Chaji  
 2013/0135272 A1 5/2013 Park  
 2013/0162617 A1 6/2013 Yoon  
 2013/0201223 A1 8/2013 Li et al.  
 2013/0309821 A1 11/2013 Yoo  
 2013/0321671 A1 12/2013 Cote  
 2014/0015824 A1 1/2014 Chaji et al.  
 2014/0043316 A1 2/2014 Chaji et al.  
 2014/0055500 A1 2/2014 Lai  
 2014/0111567 A1 4/2014 Nathan et al.

## FOREIGN PATENT DOCUMENTS

CA 2 249 592 7/1998  
 CA 2 368 386 9/1999  
 CA 2 242 720 1/2000  
 CA 2 354 018 6/2000  
 CA 2 432 530 7/2002  
 CA 2 436 451 8/2002  
 CA 2 438 577 8/2002  
 CA 2 463 653 1/2004  
 CA 2 498 136 3/2004  
 CA 2 522 396 11/2004  
 CA 2 443 206 3/2005  
 CA 2 472 671 12/2005  
 CA 2 567 076 1/2006  
 CA 2 526 782 4/2006  
 CA 2 541 531 7/2006  
 CA 2 550 102 4/2008  
 CA 2 773 699 10/2013  
 CN 1381032 11/2002  
 CN 1448908 10/2003  
 CN 1682267 A 10/2005  
 CN 1760945 4/2006  
 CN 1886774 12/2006  
 CN 101449311 6/2009  
 CN 102656621 9/2012  
 EP 0 158 366 10/1985  
 EP 1 028 471 8/2000  
 EP 1 111 577 6/2001  
 EP 1 130 565 A1 9/2001  
 EP 1 194 013 4/2002  
 EP 1 335 430 A1 8/2003  
 EP 1 372 136 12/2003  
 EP 1 381 019 1/2004  
 EP 1 418 566 5/2004  
 EP 1 429 312 A 6/2004  
 EP 145 0341 A 8/2004  
 EP 1 465 143 A 10/2004  
 EP 1 469 448 A 10/2004  
 EP 1 521 203 A2 4/2005  
 EP 1 594 347 11/2005  
 EP 1 784 055 A2 5/2007  
 EP 1854338 A1 11/2007  
 EP 1 879 169 A1 1/2008  
 EP 1 879 172 1/2008  
 EP 2395499 A1 12/2011  
 GB 2 389 951 12/2003  
 JP 1272298 10/1989  
 JP 4-042619 2/1992  
 JP 6-314977 11/1994  
 JP 8-340243 12/1996  
 JP 09-090405 4/1997  
 JP 10-254410 9/1998  
 JP 11-202295 7/1999  
 JP 11-219146 8/1999  
 JP 11 231805 8/1999  
 JP 11-282419 10/1999  
 JP 2000-056847 2/2000

(56)

## References Cited

## FOREIGN PATENT DOCUMENTS

JP	2000-81607	3/2000
JP	2001-134217	5/2001
JP	2001-195014	7/2001
JP	2002-055654	2/2002
JP	2002-91376	3/2002
JP	2002-514320	5/2002
JP	2002-229513	8/2002
JP	2002-278513	9/2002
JP	2002-333862	11/2002
JP	2003-076331	3/2003
JP	2003-124519	4/2003
JP	2003-177709	6/2003
JP	2003-271095	9/2003
JP	2003-308046	10/2003
JP	2003-317944	11/2003
JP	2004-004675	1/2004
JP	2004-045648	2/2004
JP	2004-145197	5/2004
JP	2004-287345	10/2004
JP	2005-057217	3/2005
JP	2007-065015	3/2007
JP	2007-155754	6/2007
JP	2008-102335	5/2008
JP	4-158570	10/2008
JP	2003-195813	7/2013
KR	2004-0100887	12/2004
TW	342486	10/1998
TW	473622	1/2002
TW	485337	5/2002
TW	502233	9/2002
TW	538650	6/2003
TW	1221268	9/2004
TW	1223092	11/2004
TW	200727247	7/2007
WO	WO 98/48403	10/1998
WO	WO 99/48079	9/1999
WO	WO 01/06484	1/2001
WO	WO 01/27910 A1	4/2001
WO	WO 01/63587 A2	8/2001
WO	WO 02/067327 A	8/2002
WO	WO 03/001496 A1	1/2003
WO	WO 03/034389 A	4/2003
WO	WO 03/058594 A1	7/2003
WO	WO 03/063124	7/2003
WO	WO 03/077231	9/2003
WO	WO 2004/003877	1/2004
WO	WO 2004/025615 A	3/2004
WO	WO 2004/034364	4/2004
WO	WO 2004/047058	6/2004
WO	WO 2004/104975 A1	12/2004
WO	WO 2005/022498	3/2005
WO	WO 2005/022500 A	3/2005
WO	WO 2005/029455	3/2005
WO	WO 2005/029456	3/2005
WO	WO 2005/055185	6/2005
WO	WO 2006/000101 A1	1/2006
WO	WO 2006/053424	5/2006
WO	WO 2006/063448 A	6/2006
WO	WO 2006/084360	8/2006
WO	WO 2007/003877 A	1/2007
WO	WO 2007/079572	7/2007
WO	WO 2007/120849 A2	10/2007
WO	WO 2009/048618	4/2009
WO	WO 2009/055920	5/2009
WO	WO 2010/023270	3/2010
WO	WO 2010/146707 A1	12/2010
WO	WO 2011/041224 A1	4/2011
WO	WO 2011/064761 A1	6/2011
WO	WO 2011/067729	6/2011
WO	WO 2012/160424 A1	11/2012
WO	WO 2012/160471	11/2012
WO	WO 2012/164474 A2	12/2012
WO	WO 2012/164475 A2	12/2012

## OTHER PUBLICATIONS

Alexander : "Pixel circuits and drive schemes for glass and elastic AMOLED displays"; dated Jul. 2005 (9 pages).

Alexander : "Unique Electrical Measurement Technology for Compensation, Inspection, and Process Diagnostics of AMOLED HDTV"; dated May 2010 (4 pages).

Ashfiani : "AMOLED Pixel Circuit With Electronic Compensation of Luminance Degradation"; dated Mar. 2007 (4 pages).

Chaji : "A Current-Mode Comparator for Digital Calibration of Amorphous Silicon AMOLED Displays"; dated Jul. 2008 (5 pages).

Chaji : "A fast settling current driver based on the CCI for AMOLED displays"; dated Dec. 2009 (6 pages).

Chaji : "A Low-Cost Stable Amorphous Silicon AMOLED Display with Full V~T- and V~O~L~E~D Shift Compensation"; dated May 2007 (4 pages).

Chaji : "A low-power driving scheme for a-Si:H active-matrix organic light-emitting diode displays"; dated Jun. 2005 (4 pages).

Chaji : "A low-power high-performance digital circuit for deep submicron technologies"; dated Jun. 2005 (4 pages).

Chaji : "A novel a-Si:H AMOLED pixel circuit based on short-term stress stability of a-Si:H TFTs"; dated Oct. 2005 (3 pages).

Chaji : "A Novel Driving Scheme and Pixel Circuit for AMOLED Displays"; dated Jun. 2006 (4 pages).

Chaji : "A Novel Driving Scheme for High Resolution Large-area a-Si:H AMOLED displays"; dated Aug. 2005 (3 pages).

Chaji : "A Stable Voltage-Programmed Pixel Circuit for a-Si:H AMOLED Displays"; dated Dec. 2006 (12 pages).

Chaji : "A Sub- $\mu$ A fast-settling current-programmed pixel circuit for AMOLED displays"; dated Sep. 2007.

Chaji : "An Enhanced and Simplified Optical Feedback Pixel Circuit for AMOLED Displays"; dated Oct. 2006.

Chaji : "Compensation technique for DC and transient instability of thin film transistor circuits for large-area devices"; dated Aug. 2008.

Chaji : "Driving scheme for stable operation of 2-TFT a-Si AMOLED pixel"; dated Apr. 2005 (2 pages).

Chaji : "Dynamic-effect compensating technique for stable a-Si:H AMOLED displays"; dated Aug. 2005 (4 pages).

Chaji : "Electrical Compensation of OLED Luminance Degradation"; dated Dec. 2007 (3 pages).

Chaji : "eUTDSP: a design study of a new VLIW-based DSP architecture"; dated My 2003 (4 pages).

Chaji : "Fast and Offset-Leakage Insensitive Current-Mode Line Driver for Active Matrix Displays and Sensors"; dated Feb. 2009 (8 pages).

Chaji : "High Speed Low Power Adder Design With a New Logic Style: Pseudo Dynamic Logic (SDL)"; dated Oct. 2001 (4 pages).

Chaji : "High-precision, fast current source for large-area current-programmed a-Si flat panels"; dated Sep. 2006 (4 pages).

Chaji : "Low-Cost AMOLED Television with IGNIS Compensating Technology"; dated May 2008 (4 pages).

Chaji : "Low-Cost Stable a-Si:H AMOLED Display for Portable Applications"; dated Jun. 2006 (4 pages).

Chaji : "Low-Power Low-Cost Voltage-Programmed a-Si:H AMOLED Display"; dated Jun. 2008 (5 pages).

Chaji : "Merged phototransistor pixel with enhanced near infrared response and flicker noise reduction for biomolecular imaging"; dated Nov. 2008 (3 pages).

Chaji : "Parallel Addressing Scheme for Voltage-Programmed Active-Matrix OLED Displays"; dated May 2007 (6 pages).

Chaji : "Pseudo dynamic logic (SDL): a high-speed and low-power dynamic logic family"; dated 2002 (4 pages).

Chaji : "Stable a-Si:H circuits based on short-term stress stability of amorphous silicon thin film transistors"; dated May 2006 (4 pages).

Chaji : "Stable Pixel Circuit for Small-Area High-Resolution a-Si:H AMOLED Displays"; dated Oct. 2008 (6 pages).

Chaji : "Stable RGBW AMOLED display with OLED degradation compensation using electrical feedback"; dated Feb. 2010 (2 pages).

Chaji : "Thin-Film Transistor Integration for Biomedical Imaging and AMOLED Displays"; dated 2008 (177 pages).

European Search Report for Application No. EP 04 78 6661 dated Mar. 9, 2009.

(56)

**References Cited**

## OTHER PUBLICATIONS

- European Search Report for Application No. EP 05 75 9141 dated Oct. 30, 2009 (2 pages).
- European Search Report for Application No. EP 05 81 9617 dated Jan. 30, 2009.
- European Search Report for Application No. EP 06 70 5133 dated Jul. 18, 2008.
- European Search Report for Application No. EP 06 72 1798 dated Nov. 12, 2009 (2 pages).
- European Search Report for Application No. EP 07 71 0608.6 dated Mar. 19, 2010 (7 pages).
- European Search Report for Application No. EP 07 71 9579 dated May 20, 2009.
- European Search Report for Application No. EP 07 81 5784 dated Jul. 20, 2010 (2 pages).
- European Search Report for Application No. EP 10 16 6143, dated Sep. 3, 2010 (2 pages).
- European Search Report for Application No. EP 10 83 4294.0-1903, dated Apr. 8, 2013, (9 pages).
- European Supplementary Search Report for Application No. EP 04 78 6662 dated Jan. 19, 2007 (2 pages).
- Extended European Search Report for Application No. 11 73 9485.8 mailed Aug. 6, 2013 (14 pages).
- Extended European Search Report for Application No. EP 09 73 3076.5, mailed Apr. 27, (13 pages).
- Extended European Search Report for Application No. EP 11 16 8677.0, mailed Nov. 29, 2012, (13 page).
- Extended European Search Report for Application No. EP 11 19 1641.7 mailed Jul. 11, 2012 (14 pages).
- Extended European Search Report for Application No. EP 10834297 mailed Oct. 27, 2014 (6 pages).
- Fossum, Eric R.. "Active Pixel Sensors: Are CCD's Dinosaurs?" SPIE: Symposium on Electronic Imaging. Feb. 1, 1993 (13 pages).
- Goh , "A New a-Si:H Thin-Film Transistor Pixel Circuit for Active-Matrix Organic Light-Emitting Diodes", IEEE Electron Device Letters, vol. 24, No. 9, Sep. 2003, pp. 583-585.
- International Preliminary Report on Patentability for Application No. PCT/CA2005/001007 dated Oct. 16, 2006, 4 pages.
- International Search Report for Application No. PCT/CA2004/001741 dated Feb. 21, 2005.
- International Search Report for Application No. PCT/CA2004/001742, Canadian Patent Office, dated Feb. 21, 2005 (2 pages).
- International Search Report for Application No. PCT/CA2005/001007 dated Oct. 18, 2005.
- International Search Report for Application No. PCT/CA2005/001897, mailed Mar. 21, 2006 (2 pages).
- International Search Report for Application No. PCT/CA2007/000652 dated Jul. 25, 2007.
- International Search Report for Application No. PCT/CA2009/000501, mailed Jul. 30, 2009 (4 pages).
- International Search Report for Application No. PCT/CA2009/001769, dated Apr. 8, 2010 (3 pages).
- International Search Report for Application No. PCT/IB2010/055481, dated Apr. 7, 2011, 3 pages.
- International Search Report for Application No. PCT/IB2010/055486, Dated Apr. 19, 2011, 5 pages.
- International Search Report for Application No. PCT/IB2014/060959, Dated Aug. 28, 2014, 5 pages.
- International Search Report for Application No. PCT/IB2010/055541 filed Dec. 1, 2010, dated May 26, 2011; 5 pages.
- International Search Report for Application No. PCT/IB2011/050502, dated Jun. 27, 2011 (6 pages).
- International Search Report for Application No. PCT/IB2011/051103, dated Jul. 8, 2011, 3 pages.
- International Search Report for Application No. PCT/IB2011/055135, Canadian Patent Office, dated Apr. 16, 2012 (5 pages).
- International Search Report for Application No. PCT/IB2012/052372, mailed Sep. 12, 2012 (3 pages).
- International Search Report for Application No. PCT/IB2013/054251, Canadian Intellectual Property Office, dated Sep. 11, 2013; (4 pages).
- International Search Report for Application No. PCT/JP02/09668, mailed Dec. 3, 2002, (4 pages).
- International Written Opinion for Application No. PCT/CA2004/001742, Canadian Patent Office, dated Feb. 21, 2005 (5 pages).
- International Written Opinion for Application No. PCT/CA2005/001897, mailed Mar. 21, 2006 (4 pages).
- International Written Opinion for Application No. PCT/CA2009/000501 mailed Jul. 30, 2009 (6 pages).
- International Written Opinion for Application No. PCT/IB2010/055481, dated Apr. 7, 2011, 6 pages.
- International Written Opinion for Application No. PCT/IB2010/055486, Dated Apr. 19, 2011, 8 pages.
- International Written Opinion for Application No. PCT/IB2010/055541, dated May 26, 2011; 6 pages.
- International Written Opinion for Application No. PCT/IB2011/050502, dated Jun. 27, 2011 (7 pages).
- International Written Opinion for Application No. PCT/IB2011/051103, dated Jul. 8, 2011, 6 pages.
- International Written Opinion for Application No. PCT/IB2011/055135, Canadian Patent Office, dated Apr. 16, 2012 (5 pages).
- International Written Opinion for Application No. PCT/IB2012/052372, mailed Sep. 12, 2012 (6 pages).
- International Written Opinion for Application No. PCT/IB2013/054251, Canadian Intellectual Property Office, dated Sep. 11, 2013; (5 pages).
- Jafarabadiashtiani : "A New Driving Method for a-Si AMOLED Displays Based on Voltage Feedback"; dated 2005 (4 pages).
- Kanicki, J., "Amorphous Silicon Thin-Film Transistors Based Active-Matrix Organic Light-Emitting Displays." Asia Display: International Display Workshops, Sep. 2001 (pp. 315-318).
- Karim, K. S., "Amorphous Silicon Active Pixel Sensor Readout Circuit for Digital Imaging." IEEE: Transactions on Electron Devices. vol. 50, No. 1, Jan. 2003 (pp. 200-208).
- Lee : "Ambipolar Thin-Film Transistors Fabricated by PECVD Nanocrystalline Silicon"; dated 2006.
- Lee, Wonbok: "Thermal Management in Microprocessor Chips and Dynamic Backlight Control in Liquid Crystal Displays", Ph.D. Dissertation, University of Southern California (124 pages).
- Liu, P. et al., Innovative Voltage Driving Pixel Circuit Using Organic Thin-Film Transistor for AMOLEDs, Journal of Display Technology, vol. 5, Issue 6, Jun. 2009 (pp. 224-227).
- Ma E Y: "organic light emitting diode/thin film transistor integration for foldable displays" dated Sep. 15, 1997(4 pages).
- Matsueda y : "35.1: 2.5-in. AMOLED with Integrated 6-bit Gamma Compensated Digital Data Driver"; dated May 2004.
- Mendes E., "A High Resolution Switch-Current Memory Base Cell." IEEE: Circuits and Systems. vol. 2, Aug. 1999 (pp. 718-721).
- Nathan A. , "Thin Film imaging technology on glass and plastic" ICM 2000, proceedings of the 12 international conference on microelectronics, dated Oct. 31, 2001 (4 pages).
- Nathan , "Amorphous Silicon Thin Film Transistor Circuit Integration for Organic LED Displays on Glass and Plastic", IEEE Journal of Solid-State Circuits, vol. 39, No. 9, Sep. 2004, pp. 1477-1486.
- Nathan : "Backplane Requirements for active Matrix Organic Light Emitting Diode Displays.," dated 2006 (16 pages).
- Nathan : "Call for papers second international workshop on compact thin-film transistor (TFT) modeling for circuit simulation"; dated Sep. 2009 (1 page).
- Nathan : "Driving schemes for a-Si and LTPS AMOLED displays"; dated Dec. 2005 (11 pages).
- Nathan : "Invited Paper: a-Si for AMOLED—Meeting the Performance and Cost Demands of Display Applications (Cell Phone to HDTV)"; dated 2006 (4 pages).
- Office Action in Japanese patent application No. JP2012-541612 dated Jul. 15, 2014. (3 pages).
- Partial European Search Report for Application No. EP 11 168 677.0, mailed Sep. 22, 2011 (5 pages).
- Partial European Search Report for Application No. EP 11 19 1641.7, mailed Mar. 20, 2012 (8 pages).

(56)

**References Cited**

## OTHER PUBLICATIONS

Philipp: "Charge transfer sensing" *Sensor Review*, vol. 19, No. 2, Dec. 31, 1999 (Dec. 31, 1999), 10 pages.

Rafati: "Comparison of a 17 b multiplier in Dual-rail domino and in Dual-rail D L (D L) logic styles"; dated 2002 (4 pages).

Safavian: "3-TFT active pixel sensor with correlated double sampling readout circuit for real-time medical x-ray imaging"; dated Jun. 2006 (4 pages).

Safavian: "A novel current scaling active pixel sensor with correlated double sampling readout circuit for real time medical x-ray imaging"; dated May 2007 (7 pages).

Safavian: "A novel hybrid active-passive pixel with correlated double sampling CMOS readout circuit for medical x-ray imaging"; dated May 2008 (4 pages).

Safavian: "Self-compensated a-Si:H detector with current-mode readout circuit for digital X-ray fluoroscopy"; dated Aug. 2005 (4 pages).

Safavian: "TFT active image sensor with current-mode readout circuit for digital x-ray fluoroscopy [5969D-82]"; dated Sep. 2005 (9 pages).

Safavian: "Three-TFT image sensor for real-time digital X-ray imaging"; dated Feb. 2, 2006 (2 pages).

Singh, , "Current Conveyor: Novel Universal Active Block", *Samriddhi, S-JPSET* vol. I, Issue 1, 2010, pp. 41-48 (12EPPT).

Smith, Lindsay L., "A tutorial on Principal Components Analysis," dated Feb. 26, 2001 (27 pages).

Spindler, System Considerations for RGBW OLED Displays, *Journal of the SID* 14/1, 2006, pp. 37-48.

Stewart M., "polysilicon TFT technology for active matrix oled displays" *IEEE transactions on electron devices*, vol. 48, No. 5, dated May 2001 (7 pages).

Vygranenko: "Stability of indium-oxide thin-film transistors by reactive ion beam assisted deposition"; dated 2009.

Wang: "Indium oxides by reactive ion beam assisted evaporation: From material study to device application"; dated Mar. 2009 (6 pages).

Yi He, "Current-Source a-Si:H Thin Film Transistor Circuit for Active-Matrix Organic Light-Emitting Displays", *IEEE Electron Device Letters*, vol. 21, No. 12, Dec. 2000, pp. 590-592.

Yu, Jennifer "Improve OLED Technology for Display", Ph.D. Dissertation, Massachusetts Institute of Technology, Sep. 2008 (151 pages).

International Search Report for Application No. PCT/IB2014/058244, Canadian Intellectual Property Office, dated Apr. 11, 2014; (6 pages).

International Search Report for Application No. PCT/IB2014/059753, Canadian Intellectual Property Office, dated Jun. 23, 2014; (6 pages).

Written Opinion for Application No. PCT/IB2014/059753, Canadian Intellectual Property Office, dated Jun. 12, 2014 (6 pages).

International Search Report for Application No. PCT/IB2014/060879, Canadian Intellectual Property Office, dated Jul. 17, 2014 (3 pages).

Extended European Search Report for Application No. EP 14158051.4, mailed Jul. 29, 2014, (4 pages).

Office Action in Chinese Patent Invention No. 201180008188.9, dated Jun. 4, 2014 (17 pages) (w/English translation).

International Search Report for Application No. PCT/IB/2014/066932 dated Mar. 24, 2015.

Written Opinion for Application No. PCT/IB/2014/066932 dated Mar. 24, 2015.

Extended European Search Report for Application No. EP 11866291.5, mailed Mar. 9, 2015, (9 pages).

Extended European Search Report for Application No. EP 14181848.4, mailed Mar. 5, 2015, (8 pages).

Office Action in Chinese Patent Invention No. 201280022957.5, dated Jun. 26, 2015 (7 pages).

Extended European Search Report for Application No. EP 13794695.0, mailed Dec. 18, 2015, (9 pages).

Extended European Search Report for Application No. EP 16157746.5, mailed Apr. 8, 2016, (11 pages).

FIG. 1

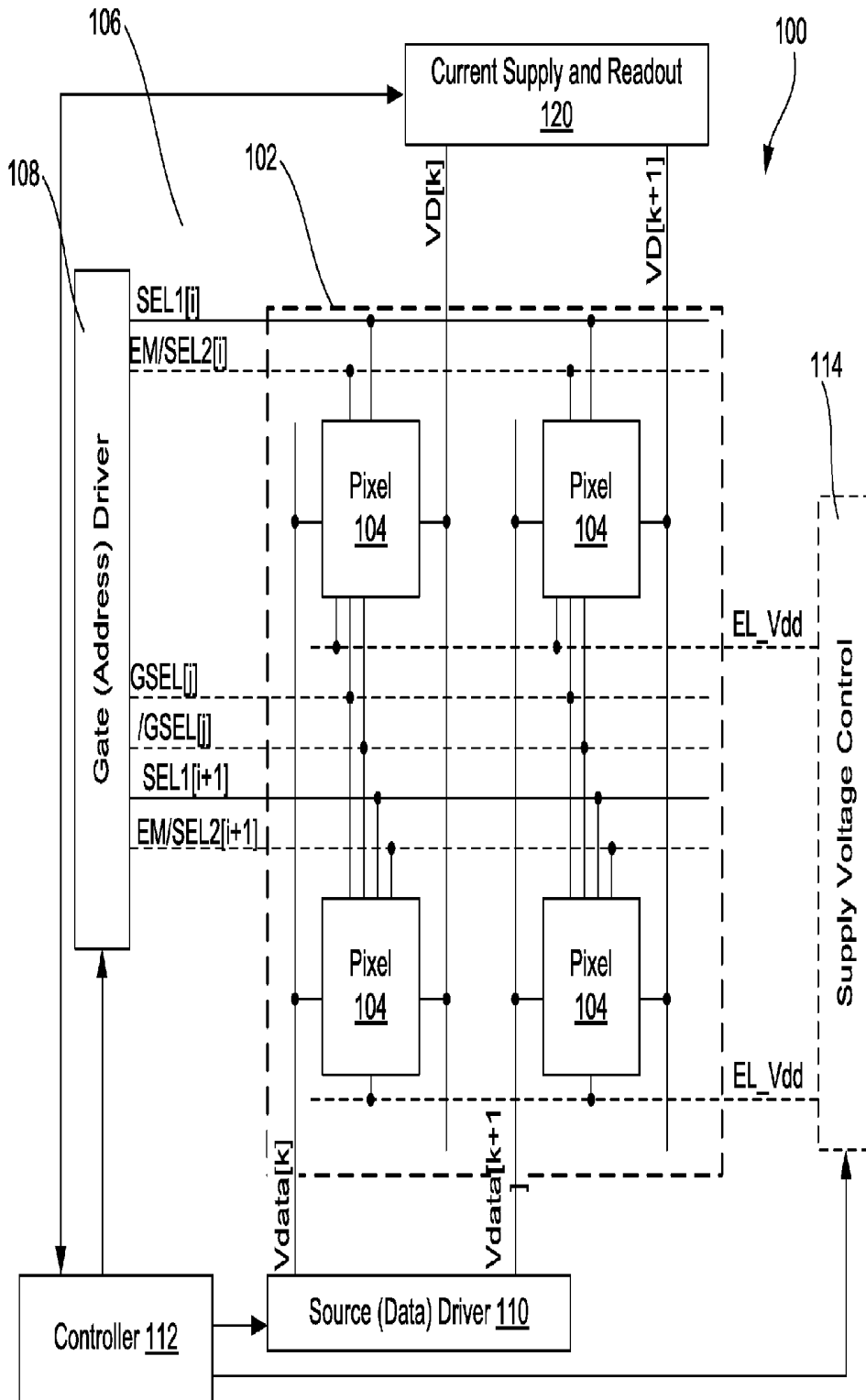
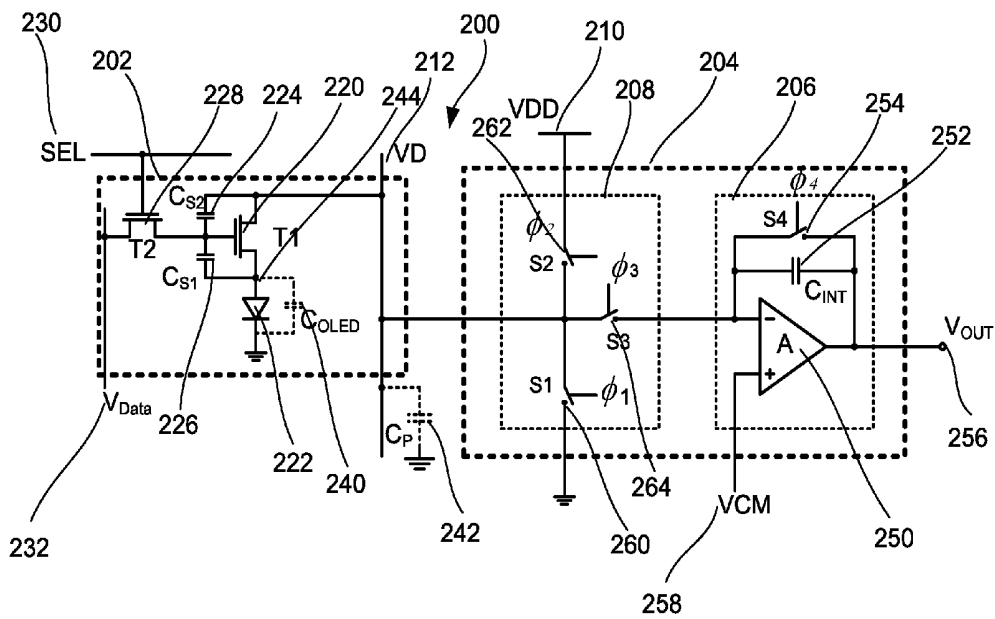

FIG. 2



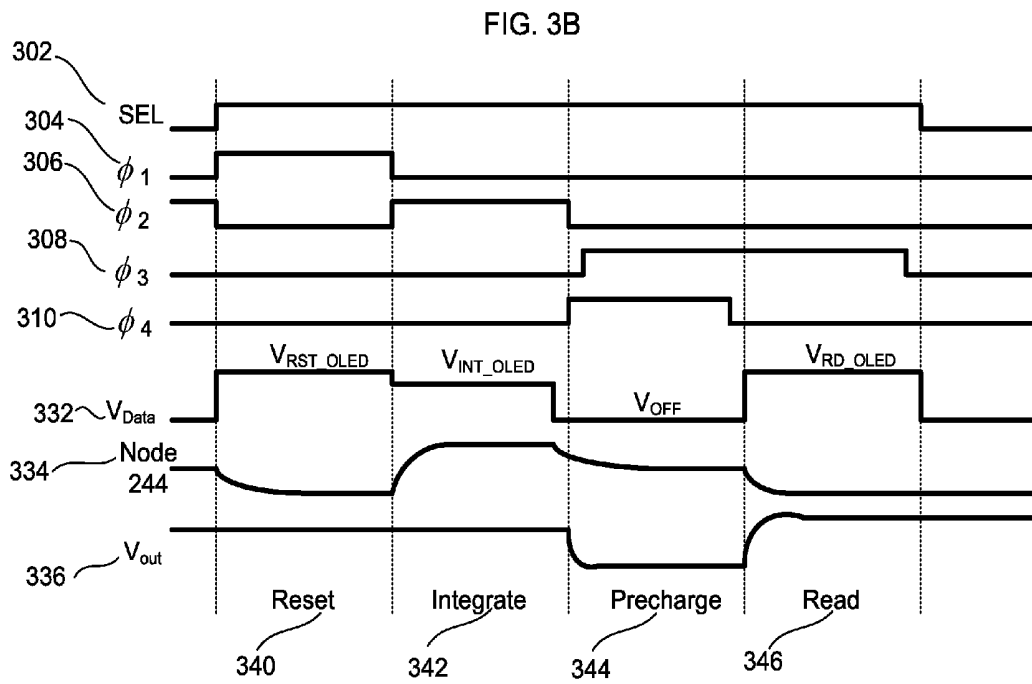
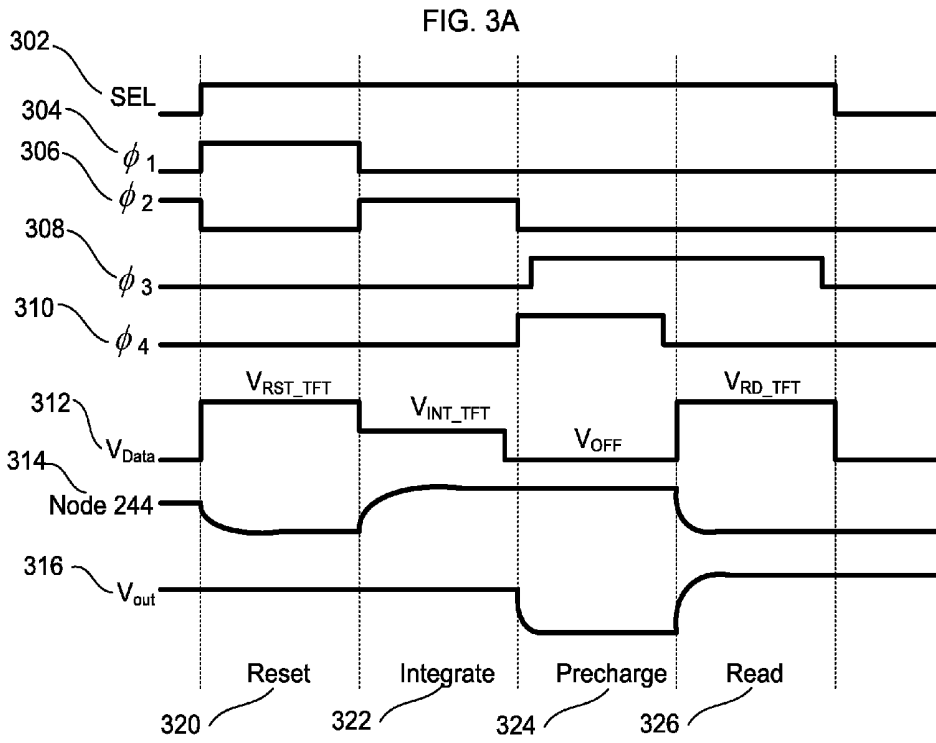

FIG. 3C

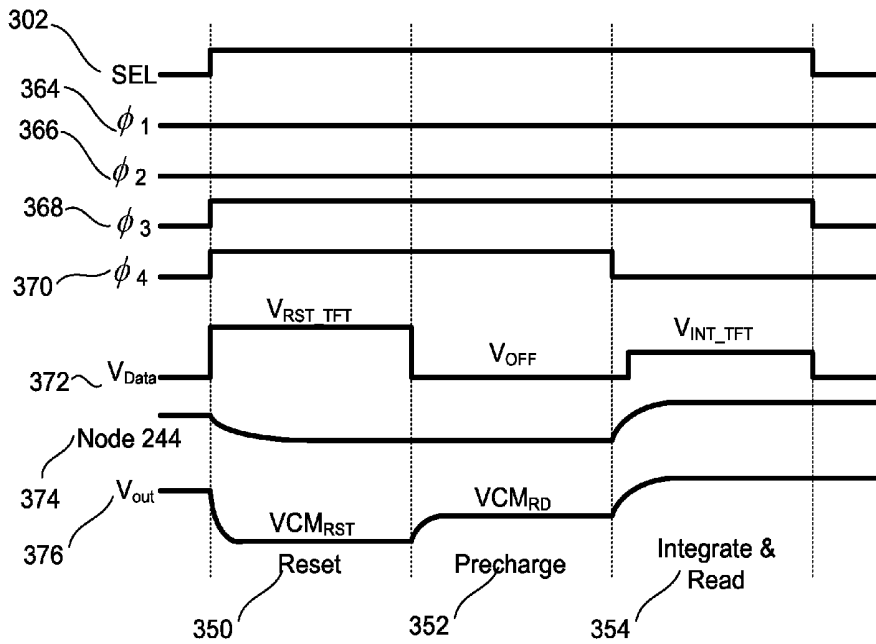
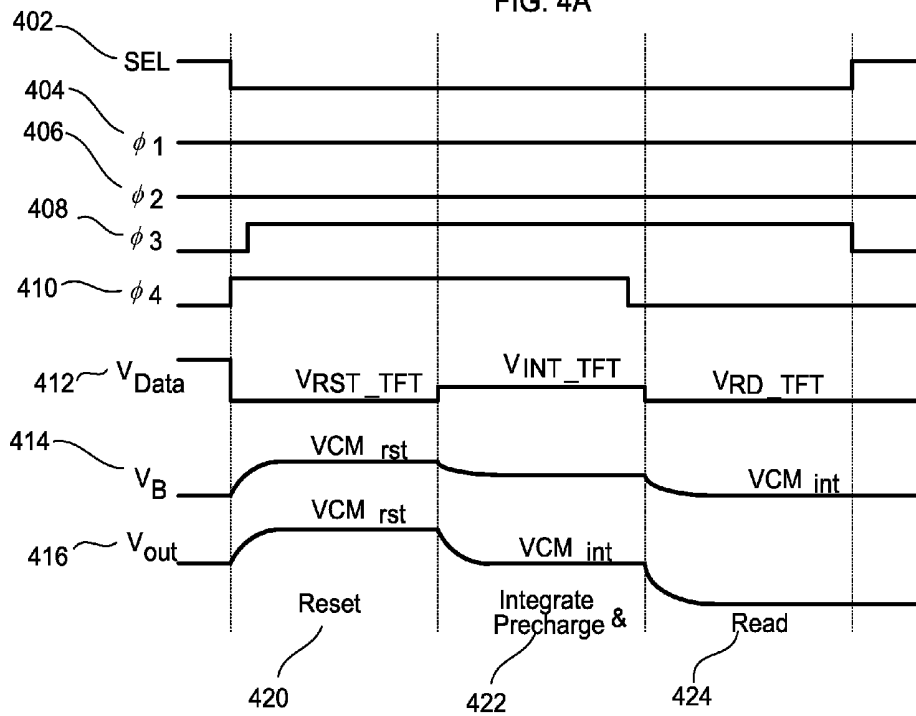

FIG. 4A



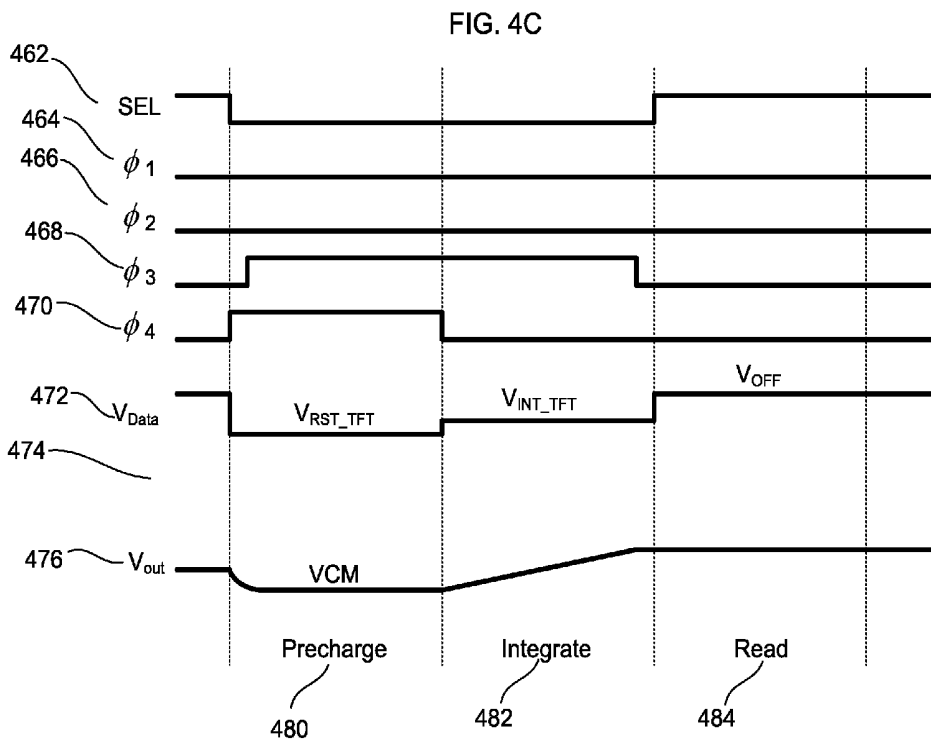
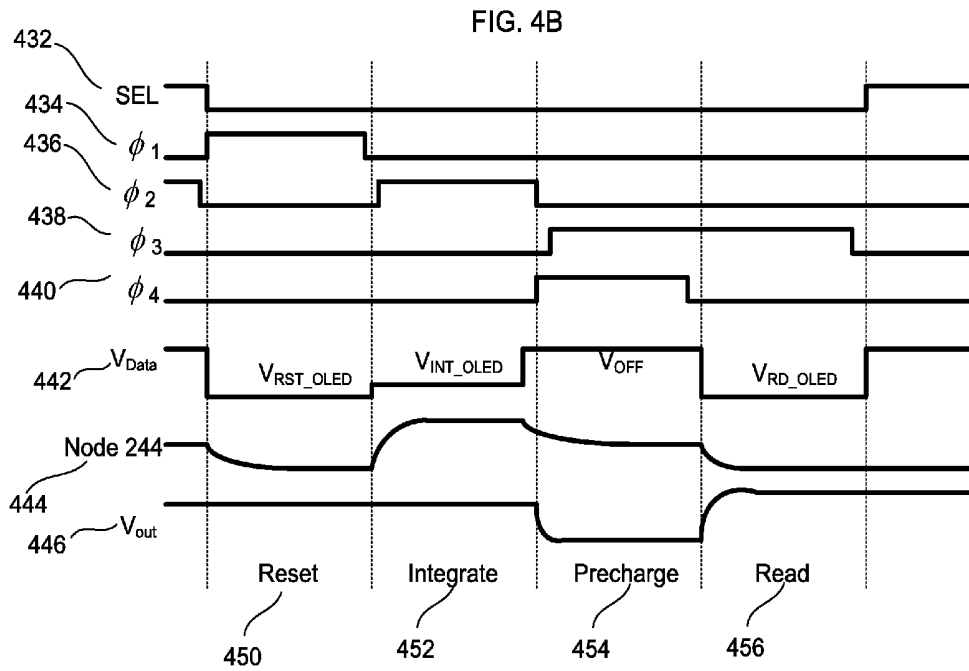
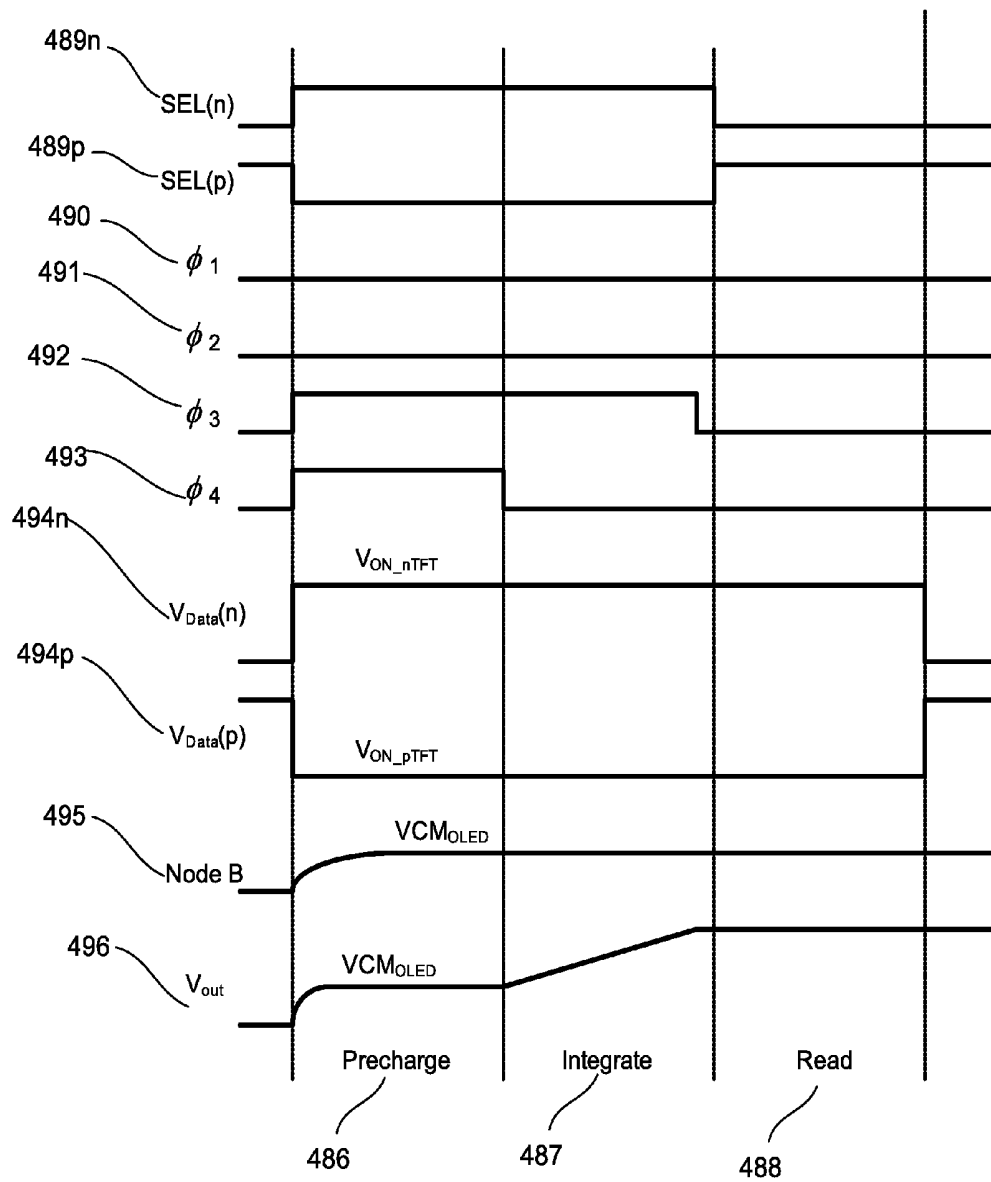

FIG. 4D



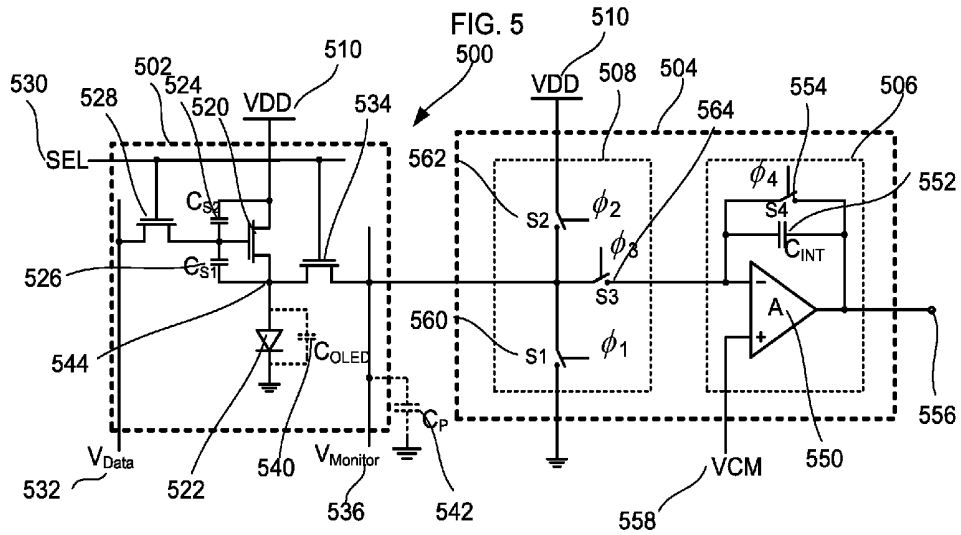

FIG. 6A

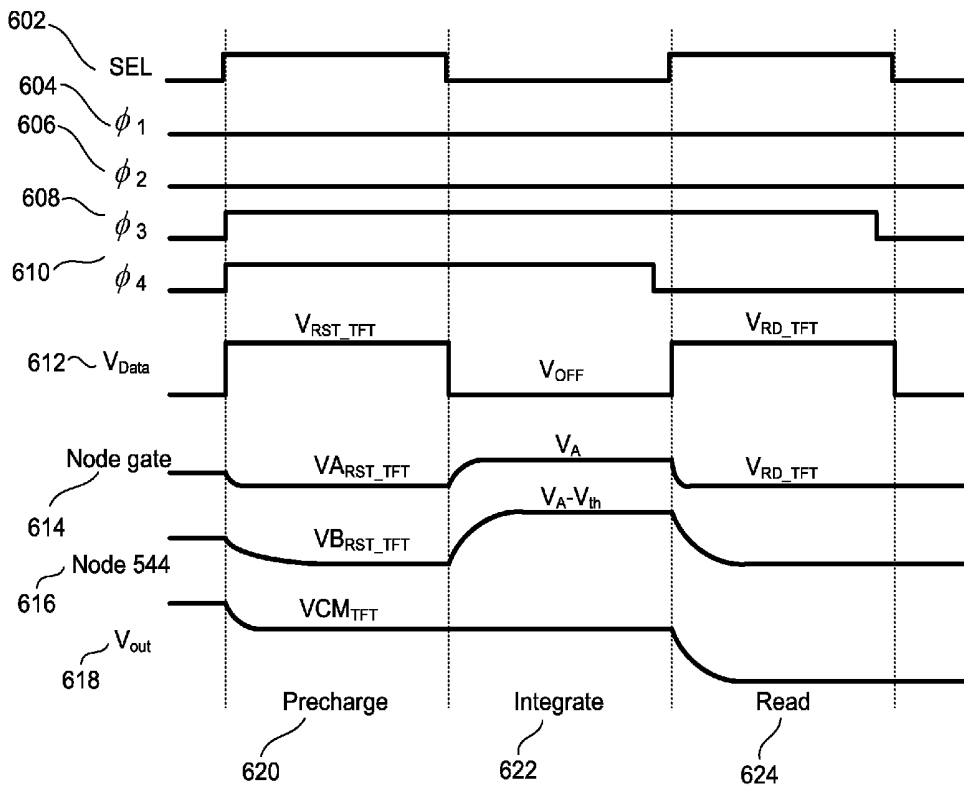

FIG. 6B

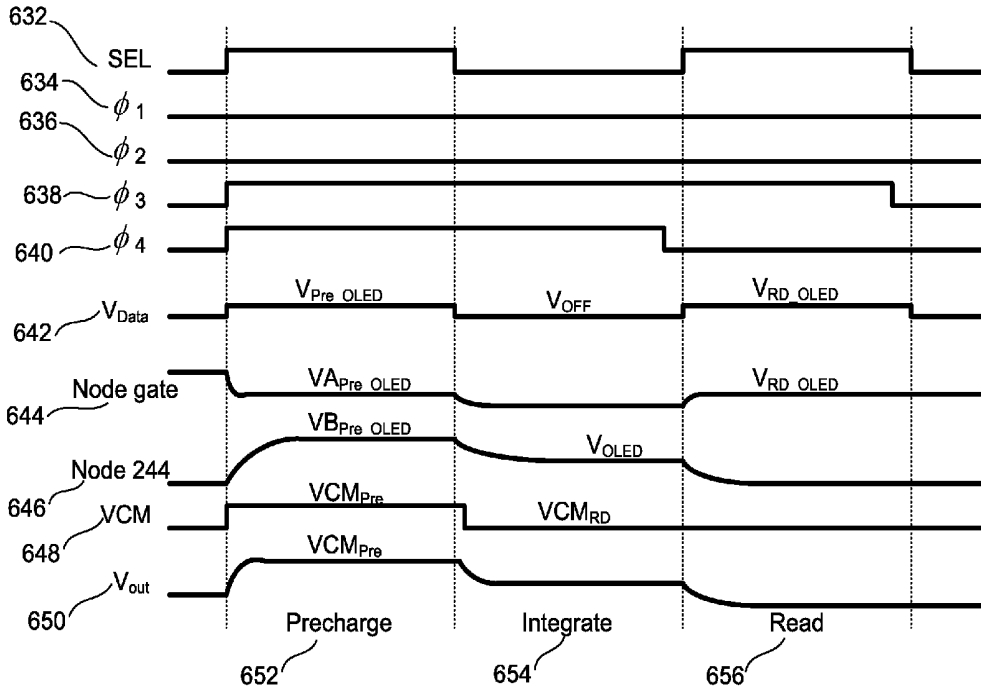

FIG. 6C

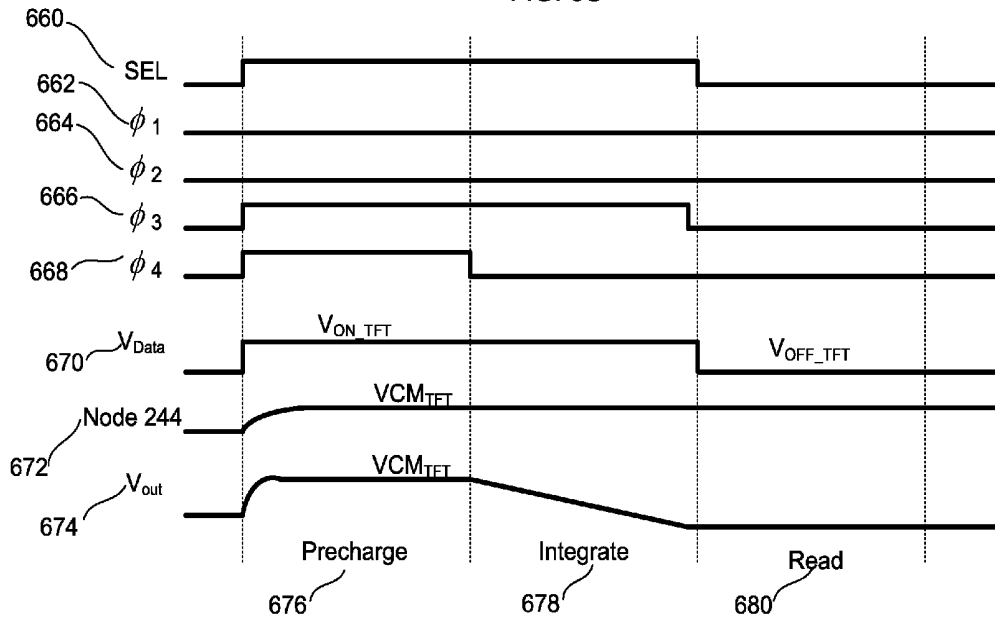

FIG. 6D

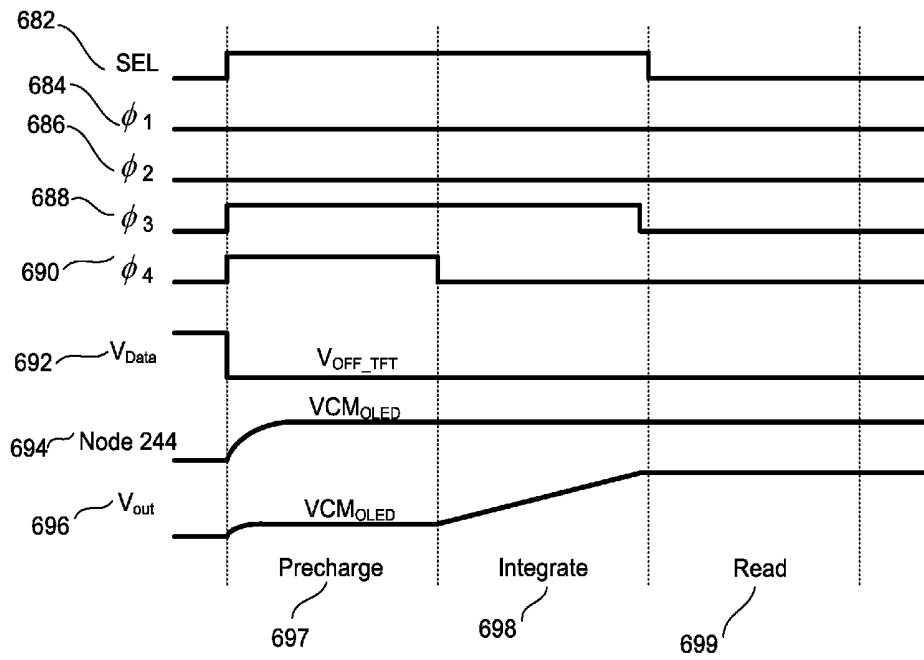

FIG. 7

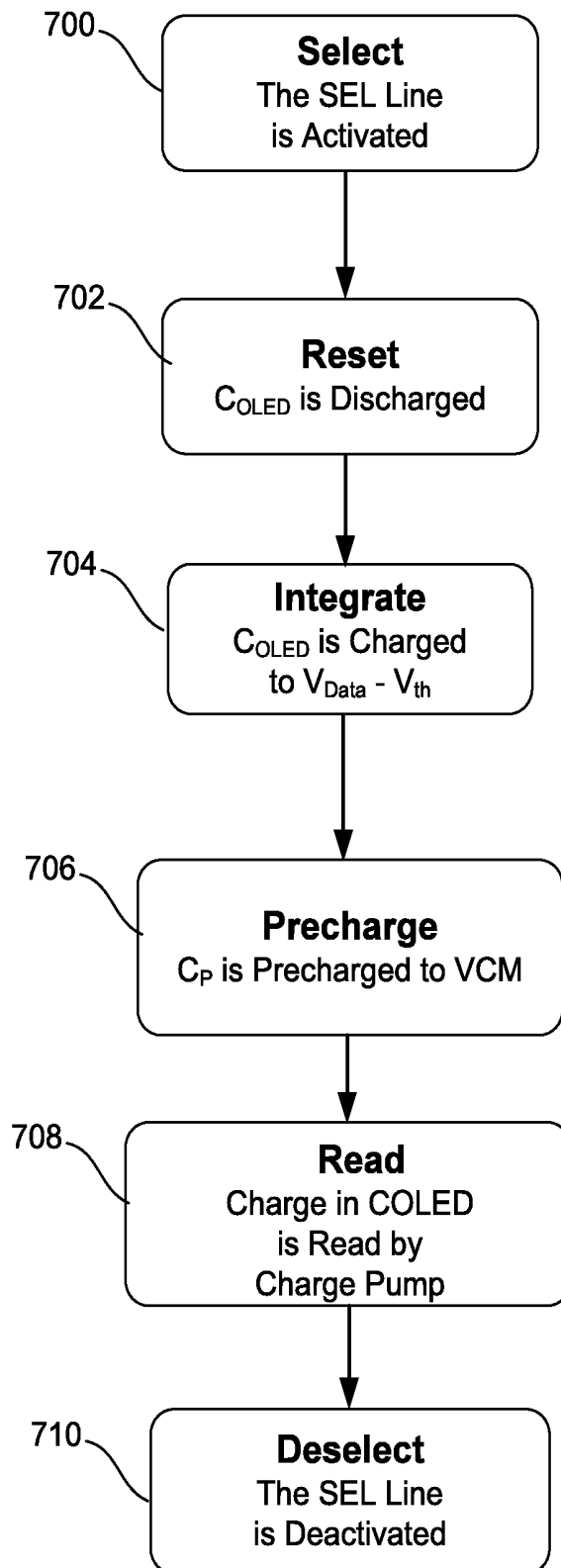

FIG. 8

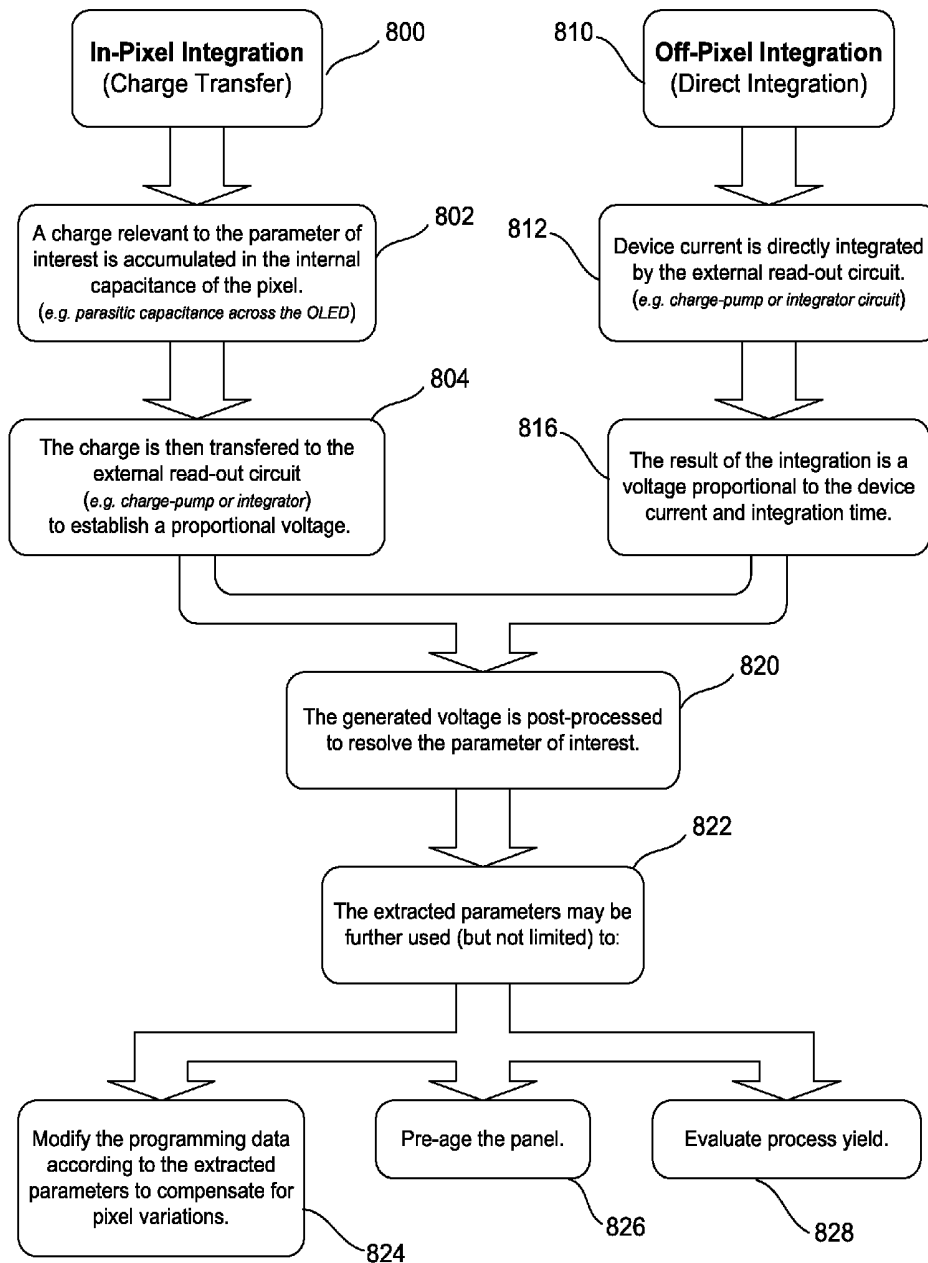
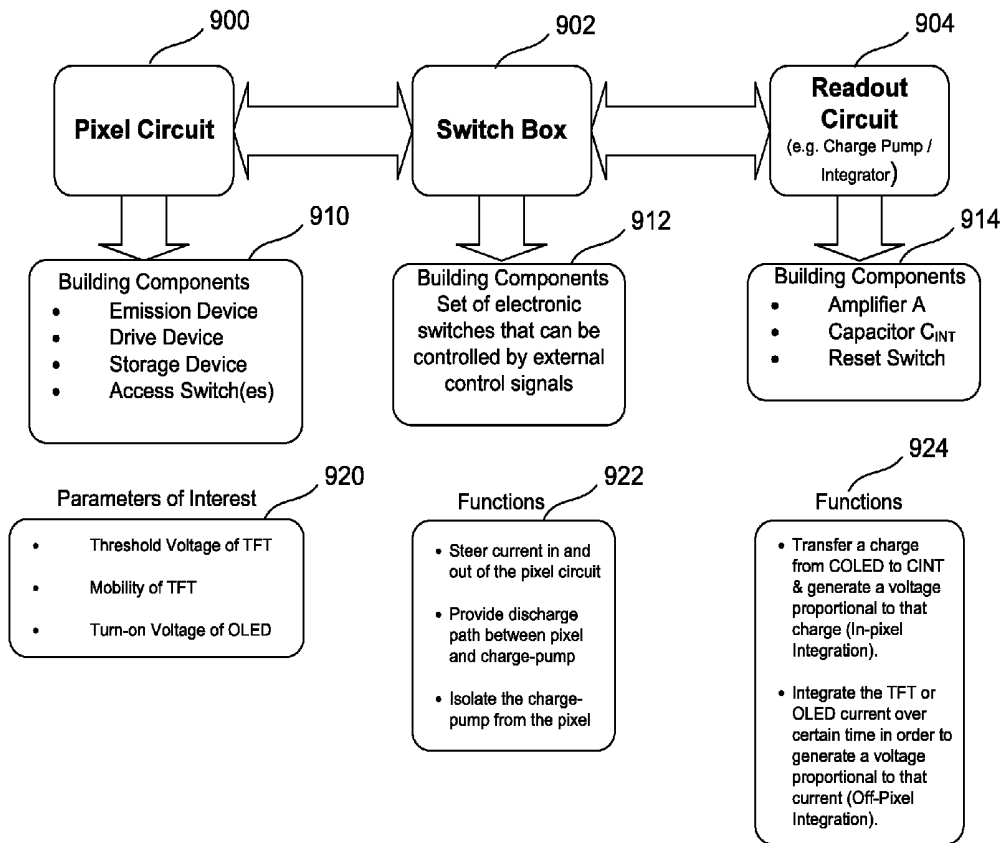

FIG. 9



**SYSTEM AND METHODS FOR  
EXTRACTION OF THRESHOLD AND  
MOBILITY PARAMETERS IN AMOLED  
DISPLAYS**

CROSS REFERENCE TO RELATED  
APPLICATIONS

This application is a continuation of, and claims priority to, U.S. patent application Ser. No. 14/680,554, filed Apr. 7, 2015, now allowed, which is a continuation of U.S. patent application Ser. No. 13/950,795, filed Jul. 25, 2013, now U.S. Pat. No. 9,093,029, which is a continuation of U.S. patent application Ser. No. 13/112,468, filed May 20, 2011, now U.S. Pat. No. 8,476,217, each of which is hereby incorporated by reference herein in its entirety.

COPYRIGHT

A portion of the disclosure of this patent document contains material which is subject to copyright protection. The copyright owner has no objection to the facsimile reproduction by anyone of the patent disclosure, as it appears in the Patent and Trademark Office patent files or records, but otherwise reserves all copyright rights whatsoever.

FIELD OF THE INVENTION

The present invention generally relates to active matrix organic light emitting device (AMOLED) displays, and particularly extracting threshold and mobility factors from the pixel drivers for such displays.

BACKGROUND

Currently, active matrix organic light emitting device ("AMOLED") displays are being introduced. The advantages of such displays include lower power consumption, manufacturing flexibility and faster refresh rate over conventional liquid crystal displays. In contrast to conventional liquid crystal displays, there is no backlighting in an AMOLED display, and thus each pixel consists of different colored OLEDs emitting light independently. The OLEDs emit light based on current supplied through a drive transistor controlled by a programming voltage. The power consumed in each pixel has a relation with the magnitude of the generated light in that pixel.

The quality of output in an OLED based pixel is affected by the properties of the drive transistor, which is typically fabricated from materials including but not limited to amorphous silicon, polysilicon, or metal oxide, as well as the OLED itself. In particular, threshold voltage and mobility of the drive transistor tend to change as the pixel ages. In order to maintain image quality, changes in these parameters must be compensated for by adjusting the programming voltage. In order to do so, such parameters must be extracted from the driver circuit. The addition of components to extract such parameters in a simple driver circuit requires more space on a display substrate for the drive circuitry and thereby reduces the amount of aperture or area of light emission from the OLED.

When biased in saturation, the I-V characteristic of a thin film drive transistor depends on mobility and threshold voltage which are a function of the materials used to fabricate the transistor. Thus different thin film transistor devices implemented across the display panel may demon-

strate non-uniform behavior due to aging and process variations in mobility and threshold voltage. Accordingly, for a constant voltage, each device may have a different drain current. An extreme example may be where one device could have low threshold-voltage and low mobility compared to a second device with high threshold-voltage and high mobility.

Thus with very few electronic components available to maintain a desired aperture, extraction of non-uniformity parameters (i.e. threshold voltage,  $V_{th}$ , and mobility,  $\mu$ ) of the drive TFT and the OLED becomes challenging. It would be desirable to extract such parameters in a driver circuit for an OLED pixel with as few components as possible to maximize pixel aperture.

SUMMARY

One example disclosed is a data extraction system for an organic light emitting device (OLED) based display. The system includes a pixel circuit including an organic light emitting device, a drive device to provide a programmable drive current to the light emitting device, a programming input to provide a programming signal, and a storage device to store the programming signal. A charge-pump amplifier has a current input and a voltage output. The charge-pump amplifier includes an operational amplifier in negative feedback configuration. The feedback is provided by a capacitor connected between the output and the inverting input of the operational amplifier. A common-mode voltage source drives the non-inverting input of the operational amplifier. An electronic switch is coupled across the capacitor to reset the capacitor. A switch module including the input is coupled to the output of the pixel circuit and an output is coupled to the input of the charge-pump amplifier. The switch module includes a plurality of electronic switches that may be controlled by external control signals to steer current in and out of the pixel circuit, provide a discharge path between the pixel circuit and the charge-pump amplifier and isolate the charge-pump amplifier from the pixel circuit. A controller is coupled to the pixel circuit, charge-pump amplifier and the switch module. The controller controls input signals to the pixel circuit, charge-pump amplifier and switch module in a predetermined sequence to produce an output voltage value which is a function of a parameter of the pixel circuit. The sequence includes providing a program voltage to the programming input to either pre-charge an internal capacitance of the pixel circuit to a charge level and transfer the charge to the charge-pump amplifier via the switch module to generate the output voltage value or provide a current from the pixel circuit to the charge-pump amplifier via the switch module to produce the output voltage value by integration over a certain period of time.

Another example is a method of extracting a circuit parameter from a pixel circuit including an organic light emitting device, a drive device to provide a programmable drive current to the light emitting device, a programming input, and a storage device to store a programming signal. A predetermined program voltage is provided to the programming voltage input. A capacitance of the pixel circuit is charged to a charge level or a current from the pixel circuit. The pixel circuit is coupled to a charge-pump amplifier. The charge-pump amplifier is isolated from the pixel circuit to provide a voltage output either proportional to the charge level or to integrate the current from the pixel circuit. The voltage output of the charge-pump amplifier is read. At least one pixel circuit parameter is determined from the voltage output of the charge-pump amplifier.

Another example is a data extraction system for an organic light emitting device (OLED) based display. The system includes a pixel circuit having a drive transistor, an organic light emitting device, and a programming input coupled to the gate of the drive transistor. The drive transistor has a source or a drain coupled to the OLED. A charge-pump amplifier has an input and an integrated voltage output. A switch module includes an input coupled to the output of the pixel circuit and an output coupled to the input of the charge-pump amplifier. The switch module includes switches to steer current in and out of the pixel circuit, provide a discharge path between the pixel circuit and the charge-pump amplifier and isolate the charge-pump amplifier from the pixel circuit. A controller is coupled to the pixel circuit, charge-pump amplifier and the switch module. The controller controls voltage inputs to the pixel circuit, charge-pump amplifier and switch module in a predetermined sequence to produce an output voltage value which is a function of a parameter of the pixel circuit. The sequence including providing a program voltage to the programming input to either pre-charge a capacitance of the pixel circuit to a charge level, transfer the charge to the charge-pump amplifier via the switch module to generate the output voltage value or provide a current from the pixel circuit to the charge-pump amplifier via the switch module to produce the output voltage value by integration.

The foregoing and additional aspects and embodiments of the present invention will be apparent to those of ordinary skill in the art in view of the detailed description of various embodiments and/or aspects, which is made with reference to the drawings, a brief description of which is provided next.

### BRIEF DESCRIPTION OF THE DRAWINGS

The foregoing and other advantages of the invention will become apparent upon reading the following detailed description and upon reference to the drawings.

FIG. 1 is a block diagram of an AMOLED display with compensation control;

FIG. 2 is a circuit diagram of a data extraction circuit for a two-transistor pixel in the AMOLED display in FIG. 1;

FIG. 3A is a signal timing diagram of the signals to the data extraction circuit to extract the threshold voltage and mobility of an n-type drive transistor in FIG. 2;

FIG. 3B is a signal timing diagram of the signals to the data extraction circuit to extract the characteristic voltage of the OLED in FIG. 2 with an n-type drive transistor;

FIG. 3C is a signal timing diagram of the signals to the data extraction circuit for a direct read to extract the threshold voltage of an n-type drive transistor in FIG. 2;

FIG. 4A is a signal timing diagram of the signals to the data extraction circuit to extract the threshold voltage and mobility of a p-type drive transistor in FIG. 2;

FIG. 4B is a signal timing diagram of the signals to the data extraction circuit to extract the characteristic voltage of the OLED in FIG. 2 with a p-type drive transistor;

FIG. 4C is a signal timing diagram of the signals to the data extraction circuit for a direct read to extract the threshold voltage of a p-type drive transistor in FIG. 2;

FIG. 4D is a signal timing diagram of the signals to the data extraction circuit for a direct read of the OLED turn-on voltage using either an n-type or p-type drive transistor in FIG. 2.

FIG. 5 is a circuit diagram of a data extraction circuit for a three-transistor drive circuit for a pixel in the AMOLED display in FIG. 1 for extraction of parameters;

FIG. 6A is a signal timing diagram of the signals to the data extraction circuit to extract the threshold voltage and mobility of the drive transistor in FIG. 5;

FIG. 6B is a signal timing diagram of the signals to the data extraction circuit to extract the characteristic voltage of the OLED in FIG. 5;

FIG. 6C is a signal timing diagram the signals to the data extraction circuit for a direct read to extract the threshold voltage of the drive transistor in FIG. 5;

FIG. 6D is a signal timing diagram of the signals to the data extraction circuit for a direct read to extract the characteristic voltage of the OLED in FIG. 5;

FIG. 7 is a flow diagram of the extraction cycle to readout the characteristics of the drive transistor and the OLED of a pixel circuit in an AMOLED display;

FIG. 8 is a flow diagram of different parameter extraction cycles and final applications; and

FIG. 9 is a block diagram and chart of the components of a data extraction system.

While the invention is susceptible to various modifications and alternative forms, specific embodiments have been shown by way of example in the drawings and will be described in detail herein. It should be understood, however, that the invention is not intended to be limited to the particular forms disclosed. Rather, the invention is to cover all modifications, equivalents, and alternatives falling within the spirit and scope of the invention as defined by the appended claims.

### DETAILED DESCRIPTION

FIG. 1 is an electronic display system 100 having an active matrix area or pixel array 102 in which an nxm array of pixels 104 are arranged in a row and column configuration. For ease of illustration, only two rows and two columns are shown. External to the active matrix area of the pixel array 102 is a peripheral area 106 where peripheral circuitry for driving and controlling the pixel array 102 are disposed.

The peripheral circuitry includes an address or gate driver circuit 108, a data or source driver circuit 110, a controller 112, and an optional supply voltage (e.g., Vdd) driver 114. The controller 112 controls the gate, source, and supply voltage drivers 108, 110, 114. The gate driver 108, under control of the controller 112, operates on address or select lines SEL[j], SEL[j+1], and so forth, one for each row of pixels 104 in the pixel array 102. In pixel sharing configurations described below, the gate or address driver circuit 108 can also optionally operate on global select lines GSEL[j] and optionally /GSEL[j], which operate on multiple rows of pixels 104 in the pixel array 102, such as every two rows of pixels 104. The source driver circuit 110, under control of the controller 112, operates on voltage data lines Vdata[k], Vdata[k+1], and so forth, one for each column of pixels 104 in the pixel array 102. The voltage data lines carry voltage programming information to each pixel 104 indicative of the brightness of each light emitting device in the pixel 104. A storage element, such as a capacitor, in each pixel 104 stores the voltage programming information until an emission or driving cycle turns on the light emitting device. The optional supply voltage driver 114, under control of the controller 112, controls a supply voltage (EL\_Vdd) line, one for each row or column of pixels 104 in the pixel array 102.

The display system 100 further includes a current supply and readout circuit 120, which reads output data from data output lines, VD [k], VD [k+1], and so forth, one for each column of pixels 104 in the pixel array 102.

As is known, each pixel **104** in the display system **100** needs to be programmed with information indicating the brightness of the light emitting device in the pixel **104**. A frame defines the time period that includes: (i) a programming cycle or phase during which each and every pixel in the display system **100** is programmed with a programming voltage indicative of a brightness; and (ii) a driving or emission cycle or phase during which each light emitting device in each pixel is turned on to emit light at a brightness commensurate with the programming voltage stored in a storage element. A frame is thus one of many still images that compose a complete moving picture displayed on the display system **100**. There are at least schemes for programming and driving the pixels: row-by-row, or frame-by-frame. In row-by-row programming, a row of pixels is programmed and then driven before the next row of pixels is programmed and driven. In frame-by-frame programming, all rows of pixels in the display system **100** are programmed first, and all rows of pixels are driven at once. Either scheme can employ a brief vertical blanking time at the beginning or end of each frame during which the pixels are neither programmed nor driven.

The components located outside of the pixel array **102** may be disposed in a peripheral area **106** around the pixel array **102** on the same physical substrate on which the pixel array **102** is disposed. These components include the gate driver **108**, the source driver **110**, the optional supply voltage driver **114**, and a current supply and readout circuit **120**. Alternately, some of the components in the peripheral area **106** may be disposed on the same substrate as the pixel array **102** while other components are disposed on a different substrate, or all of the components in the peripheral area can be disposed on a substrate different from the substrate on which the pixel array **102** is disposed. Together, the gate driver **108**, the source driver **110**, and the supply voltage driver **114** make up a display driver circuit. The display driver circuit in some configurations can include the gate driver **108** and the source driver **110** but not the supply voltage control **114**.

When biased in saturation, the first order I-V characteristic of a metal oxide semiconductor (MOS) transistor (a thin film transistor in this case of interest) is modeled as:

$$I_D = \frac{1}{2} \mu C_{ox} \frac{W}{L} (V_{GS} - V_{th})^2$$

where  $I_D$  is the drain current and  $V_{GS}$  is the voltage difference applied between gate and source terminals of the transistor. The thin film transistor devices implemented across the display system **100** demonstrate non-uniform behavior due to aging and process variations in mobility ( $\mu$ ) and threshold voltage ( $V_{th}$ ). Accordingly, for a constant voltage difference applied between gate and source,  $V_{GS}$ , each transistor on the pixel matrix **102** may have a different drain current based on a non-deterministic mobility and threshold voltage:

$$I_{D(i,j)} = f(\mu_{i,j}, V_{th_{i,j}})$$

where  $i$  and  $j$  are the coordinates (row and column) of a pixel in an  $n \times m$  array of pixels such as the array of pixels **102** in FIG. **1**.

FIG. **2** shows a data extraction system **200** including a two-transistor (2T) driver circuit **202** and a readout circuit **204**. The supply voltage control **114** is optional in a display system with 2T pixel circuit **104**. The readout circuit **204** is part of the current supply and readout circuit **120** and gathers

data from a column of pixels **104** as shown in FIG. **1**. The readout circuit **204** includes a charge pump circuit **206** and a switch-box circuit **208**. A voltage source **210** provides the supply voltage to the driver circuit **202** through the switch-box circuit **208**. The charge-pump and switch-box circuits **206** and **208** are implemented on the top or bottom side of the array **102** such as in the voltage drive **114** and the current supply and readout circuit **120** in FIG. **1**. This is achieved by either direct fabrication on the same substrate as the pixel array **102** or by bonding a microchip on the substrate or a flex as a hybrid solution.

The driver circuit **202** includes a drive transistor **220**, an organic light emitting device **222**, a drain storage capacitor **224**, a source storage capacitor **226**, and a select transistor **228**. A supply line **212** provides the supply voltage and also a monitor path (for the readout circuit **204**) to a column of driver circuits such as the driver circuit **202**. A select line input **230** is coupled to the gate of the select transistor **228**. A programming data input **232** is coupled to the gate of the drive transistor **220** through the select transistor **228**. The drain of the drive transistor **220** is coupled to the supply voltage line **212** and the source of the drive transistor **220** is coupled to the OLED **222**. The select transistor **228** controls the coupling of the programming input **230** to the gate of the drive transistor **220**. The source storage capacitor **226** is coupled between the gate and the source of the drive transistor **220**. The drain storage capacitor **224** is coupled between the gate and the drain of the drive transistor **220**. The OLED **222** has a parasitic capacitance that is modeled as a capacitor **240**. The supply voltage line **212** also has a parasitic capacitance that is modeled as a capacitor **242**. The drive transistor **220** in this example is a thin film transistor that is fabricated from amorphous silicon. Of course other materials such as polysilicon or metal oxide may be used. A node **244** is the circuit node where the source of the drive transistor **220** and the anode of the OLED **222** are coupled together. In this example, the drive transistor **220** is an n-type transistor. The system **200** may be used with a p-type drive transistor in place of the n-type drive transistor **220** as will be explained below.

The readout circuit **204** includes the charge-pump circuit **206** and the switch-box circuit **208**. The charge-pump circuit **206** includes an amplifier **250** having a positive and negative input. The negative input of the amplifier **250** is coupled to a capacitor **252** ( $C_{int}$ ) in parallel with a switch **254** in a negative feedback loop to an output **256** of the amplifier **250**. The switch **254** (S4) is utilized to discharge the capacitor **252**  $C_{int}$  during the pre-charge phase. The positive input of the amplifier **250** is coupled to a common mode voltage input **258** (VCM). The output **256** of the amplifier **250** is indicative of various extracted parameters of the drive transistor **220** and OLED **222** as will be explained below.

The switch-box circuit **208** includes several switches **260**, **262** and **264** (S1, S2 and S3) to steer current to and from the pixel driver circuit **202**. The switch **260** (S1) is used during the reset phase to provide a discharge path to ground. The switch **262** (S2) provides the supply connection during normal operation of the pixel **104** and also during the integration phase of readout. The switch **264** (S3) is used to isolate the charge-pump circuit **206** from the supply line voltage **212** (VD).

The general readout concept for the two transistor pixel driver circuit **202** for each of the pixels **104**, as shown in FIG. **2**, comes from the fact that the charge stored on the parasitic capacitance represented by the capacitor **240** across the OLED **222** has useful information of the threshold voltage and mobility of the drive transistor **220** and the

turn-on voltage of the OLED 222. The extraction of such parameters may be used for various applications. For example, such parameters may be used to modify the programming data for the pixels 104 to compensate for pixel variations and maintain image quality. Such parameters may also be used to pre-age the pixel array 102. The parameters may also be used to evaluate the process yield for the fabrication of the pixel array 102.

Assuming that the capacitor 240 ( $C_{OLED}$ ) is initially discharged, it takes some time for the capacitor 240 ( $C_{OLED}$ ) to charge up to a voltage level that turns the drive transistor 220 off. This voltage level is a function of the threshold voltage of the drive transistor 220. The voltage applied to the programming data input 232 ( $V_{Data}$ ) must be low enough such that the settled voltage of the OLED 222 ( $V_{OLED}$ ) is less than the turn-on threshold voltage of the OLED 222 itself. In this condition,  $V_{Data} - V_{OLED}$  is a linear function of the threshold voltage ( $V_{th}$ ) of the drive transistor 220. In order to extract the mobility of a thin film transistor device such as the drive transistor 220, the transient settling of such devices, which is a function of both the threshold voltage and mobility, is considered. Assuming that the threshold voltage deviation among the TFT devices such as the drive transistor 220 is compensated, the voltage of the node 244 sampled at a constant interval after the beginning of integration is a function of mobility only of the TFT device such as the drive transistor 220 of interest.

FIG. 3A-3C are signal timing diagrams of the control signals applied to the components in FIG. 2 to extract parameters such as voltage threshold and mobility from the drive transistor 220 and the turn on voltage of the OLED 222 in the drive circuit 200 assuming the drive transistor 220 is an n-type transistor. Such control signals could be applied by the controller 112 to the source driver 110, the gate driver 108 and the current supply and readout circuit 120 in FIG. 1. FIG. 3A is a timing diagram showing the signals applied to the extraction circuit 200 to extract the threshold voltage and mobility from the drive transistor 220. FIG. 3A includes a signal 302 for the select input 230 in FIG. 2, a signal 304 ( $\phi_1$ ) to the switch 260, a signal 306 ( $\phi_2$ ) for the switch 262, a signal 308 ( $\phi_3$ ) for the switch 264, a signal 310 ( $\phi_4$ ) for the switch 254, a programming voltage signal 312 for the programming data input 232 in FIG. 2, a voltage 314 of the node 244 in FIG. 2 and an output voltage signal 316 for the output 256 of the amplifier 250 in FIG. 2.

FIG. 3A shows the four phases of the readout process, a reset phase 320, an integration phase 322, a pre-charge phase 324 and a read phase 326. The process starts by activating a high select signal 302 to the select input 230. The select signal 302 will be kept high throughout the readout process as shown in FIG. 3A.

During the reset phase 320, the input signal 304 ( $\phi_1$ ) to the switch 260 is set high in order to provide a discharge path to ground. The signals 306, 308 and 310 ( $\phi_2, \phi_3, \phi_4$ ) to the switches 262, 264 and 250 are kept low in this phase. A high enough voltage level ( $V_{RST\_TFT}$ ) is applied to the programming data input 232 ( $V_{Data}$ ) to maximize the current flow through the drive transistor 220. Consequently, the voltage at the node 244 in FIG. 2 is discharged to ground to get ready for the next cycle.

During the integration phase 322, the signal 304 ( $\phi_2$ ) to the switch 262 stays high which provides a charging path from the voltage source 210 through the switch 262. The signals 304, 308 and 310 ( $\phi_1, \phi_3, \phi_4$ ) to the switches 260, 264 and 250 are kept low in this phase. The programming voltage input 232 ( $V_{Data}$ ) is set to a voltage level ( $V_{INT\_TFT}$ ) such that once the capacitor 240 ( $C_{oled}$ ) is fully charged, the

voltage at the node 244 is less than the turn-on voltage of the OLED 222. This condition will minimize any interference from the OLED 222 during the reading of the drive transistor 220. Right before the end of integration time, the signal 312 to the programming voltage input 232 ( $V_{Data}$ ) is lowered to  $V_{OFF}$  in order to isolate the charge on the capacitor 240 ( $C_{oled}$ ) from the rest of the circuit.

When the integration time is long enough, the charge stored on capacitor 240 ( $C_{oled}$ ) will be a function of the threshold voltage of the drive transistor 220. For a shortened integration time, the voltage at the node 244 will experience an incomplete settling and the stored charge on the capacitor 240 ( $C_{oled}$ ) will be a function of both the threshold voltage and mobility of the drive transistor 220. Accordingly, it is feasible to extract both parameters by taking two separate readings with short and long integration phases.

During the pre-charge phase 324, the signals 304 and 306 ( $\phi_1, \phi_2$ ) to switches 260 and 262 are set low. Once the input signal 310 ( $\phi_4$ ) to the switch 254 is set high, the amplifier 250 is set in a unity feedback configuration. In order to protect the output stage of the amplifier 250 against short-circuit current from the supply voltage 210, the signal 308 ( $\phi_3$ ) to the switch 264 goes high when the signal 306 ( $\phi_2$ ) to the switch 262 is set low. When the switch 264 is closed, the parasitic capacitance 242 of the supply line is precharged to the common mode voltage, VCM. The common mode voltage, VCM, is a voltage level which must be lower than the ON voltage of the OLED 222. Right before the end of pre-charge phase, the signal 310 ( $\phi_4$ ) to the switch 254 is set low to prepare the charge pump amplifier 250 for the read cycle.

During the read phase 326, the signals 304, 306 and 310 ( $\phi_1, \phi_2, \phi_4$ ) to the switches 260, 262 and 254 are set low. The signal 308 ( $\phi_3$ ) to the switch 264 is kept high to provide a charge transfer path from the drive circuit 202 to the charge-pump amplifier 250. A high enough voltage 312 ( $V_{RD\_TFT}$ ) is applied to the programming voltage input 232 ( $V_{Data}$ ) to minimize the channel resistance of the drive transistor 220. If the integration cycle is long enough, the accumulated charge on the capacitor 252 ( $C_{int}$ ) is not a function of integration time. Accordingly, the output voltage of the charge-pump amplifier 250 in this case is equal to:

$$V_{out} = -\frac{C_{oled}}{C_{int}}(V_{Data} - V_{th})$$

For a shortened integration time, the accumulated charge on the capacitor 252 ( $C_{int}$ ) is given by:

$$Q_{int} = \int_0^{T_{int}} i_D(V_{GS}, V_{th}, \mu) \cdot dt$$

Consequently, the output voltage 256 of the charge-pump amplifier 250 at the end of read cycle equals:

$$V_{out} = -\frac{1}{C_{int}} \cdot \int_0^{T_{int}} i_D(V_{GS}, V_{th}, \mu) \cdot dt$$

Hence, the threshold voltage and the mobility of the drive transistor 220 may be extracted by reading the output voltage 256 of the amplifier 250 in the middle and at the end of the read phase 326.

FIG. 3B is a timing diagram for the reading process of the threshold turn-on voltage parameter of the OLED 222 in FIG. 2. The reading process of the OLED 222 also includes four phases, a reset phase 340, an integration phase 342, a pre-charge phase 344 and a read phase 346. Just like the reading process for the drive transistor 220 in FIG. 3A, the reading process for OLED starts by activating the select input 230 with a high select signal 302. The timing of the signals 304, 306, 308, and 310 ( $\phi_1, \phi_2, \phi_3, \phi_4$ ) to the switches 260, 262, 264 and 254 is the same as the read process for the drive transistor 220 in FIG. 3A. A programming signal 332 for the programming input 232, a signal 334 for the node 244 and an output signal 336 for the output of the amplifier 250 are different from the signals in FIG. 3A.

During the reset phase 340, a high enough voltage level 332 ( $V_{RST\_OLED}$ ) is applied to the programming data input 232 ( $V_{Data}$ ) to maximize the current flow through the drive transistor 220. Consequently, the voltage at the node 244 in FIG. 2 is discharged to ground through the switch 260 to get ready for the next cycle.

During the integration phase 342, the signal 306 ( $\phi_2$ ) to the switch 262 stays high which provides a charging path from the voltage source 210 through the switch 262. The programming voltage input 232 ( $V_{Data}$ ) is set to a voltage level 332 ( $V_{INT\_OLED}$ ) such that once the capacitor 240 ( $C_{oled}$ ) is fully charged, the voltage at the node 244 is greater than the turn-on voltage of the OLED 222. In this case, by the end of the integration phase 342, the drive transistor 220 is driving a constant current through the OLED 222.

During the pre-charge phase 344, the drive transistor 220 is turned off by the signal 332 to the programming input 232. The capacitor 240 ( $C_{oled}$ ) is allowed to discharge until it reaches the turn-on voltage of OLED 222 by the end of the pre-charge phase 344.

During the read phase 346, a high enough voltage 332 ( $V_{RD\_OLED}$ ) is applied to the programming voltage input 232 ( $V_{Data}$ ) to minimize the channel resistance of the drive transistor 220. If the pre-charge phase is long enough, the settled voltage across the capacitor 252 ( $C_{int}$ ) will not be a function of pre-charge time. Consequently, the output voltage 256 of the charge-pump amplifier 250 at the end of the read phase is given by:

$$V_{out} = -\frac{C_{oled}}{C_{int}} \cdot V_{ON,oled}$$

The signal 308 ( $\phi_3$ ) to the switch 264 is kept high to provide a charge transfer path from the drive circuit 202 to the charge-pump amplifier 250. Thus the output voltage signal 336 may be used to determine the turn-on voltage of the OLED 220.

FIG. 3C is a timing diagram for the direct reading of the drive transistor 220 using the extraction circuit 200 in FIG. 2. The direct reading process has a reset phase 350, a pre-charge phase 352 and an integrate/read phase 354. The readout process is initiated by activating the select input 230 in FIG. 2. The select signal 302 to the select input 230 is kept high throughout the readout process as shown in FIG. 3C. The signals 364 and 366 ( $\phi_1, \phi_2$ ) for the switches 260 and 262 are inactive in this readout process.

During the reset phase 350, the signals 368 and 370 ( $\phi_3, \phi_4$ ) for the switches 264 and 254 are set high in order to provide a discharge path to virtual ground. A high enough voltage 372 ( $V_{RST\_IFT}$ ) is applied to the programming input 232 ( $V_{Data}$ ) to maximize the current flow through the drive

transistor 220. Consequently, the node 244 is discharged to the common-mode voltage 374 ( $V_{CM\_RST}$ ) to get ready for the next cycle.

During the pre-charge phase 354, the drive transistor 220 is turned off by applying an off voltage 372 ( $V_{OFF}$ ) to the programming input 232 in FIG. 2. The common-mode voltage input 258 to the positive input of the amplifier 250 is raised to  $V_{CM\_RD}$  in order to precharge the line capacitance. At the end of the pre-charge phase 354, the signal 370 ( $\phi_4$ ) to the switch 254 is turned off to prepare the charge-pump amplifier 250 for the next cycle.

At the beginning of the read/integrate phase 356, the programming voltage input 232 ( $V_{Data}$ ) is raised to  $V_{INT\_TFT}$  372 to turn the drive transistor 220 on. The capacitor 240 ( $C_{OLED}$ ) starts to accumulate the charge until  $V_{Data}$  minus the voltage at the node 244 is equal to the threshold voltage of the drive transistor 220. In the meantime, a proportional charge is accumulated in the capacitor 252 ( $C_{INT}$ ). Accordingly, at the end of the read cycle 356, the output voltage 376 at the output 256 of the amplifier 250 is a function of the threshold voltage which is given by:

$$V_{out} = \frac{C_{oled}}{C_{int}} \cdot (V_{Data} - V_{th})$$

As indicated by the above equation, in the case of the direct reading, the output voltage has a positive polarity. Thus, the threshold voltage of the drive transistor 220 may be determined by the output voltage of the amplifier 250.

As explained above, the drive transistor 220 in FIG. 2 may be a p-type transistor. FIG. 4A-4C are signal timing diagrams of the signals applied to the components in FIG. 2 to extract voltage threshold and mobility from the drive transistor 220 and the OLED 222 when the drive transistor 220 is a p-type transistor. In the example where the drive transistor 220 is a p-type transistor, the source of the drive transistor 220 is coupled to the supply line 212 (VD) and the drain of the drive transistor 220 is coupled to the OLED 222. FIG. 4A is a timing diagram showing the signals applied to the extraction circuit 200 to extract the threshold voltage and mobility from the drive transistor 220 when the drive transistor 220 is a p-type transistor. FIG. 4A shows voltage signals 402-416 for the select input 232, the switches 260, 262, 264 and 254, the programming data input 230, the voltage at the node 244 and the output voltage 256 in FIG. 2. The data extraction is performed in three phases, a reset phase 420, an integrate/pre-charge phase 422, and a read phase 424.

As shown in FIG. 4A, the select signal 402 is active low and kept low throughout the readout phases 420, 422 and 424. Throughout the readout process, the signals 404 and 406 ( $\phi_1, \phi_2$ ) to the switches 260 and 262 are kept low (inactive). During the reset phase, the signals 408 and 410 ( $\phi_3, \phi_4$ ) at the switches 264 and 254 are set to high in order to charge the node 244 to a reset common mode voltage level  $V_{CM\_rst}$ . The common-mode voltage input 258 on the charge-pump input 258 ( $V_{CM\_rst}$ ) should be low enough to keep the OLED 222 off. The programming data input 232  $V_{Data}$  is set to a low enough value 412 ( $V_{RST\_IFT}$ ) to provide maximum charging current through the driver transistor 220.

During the integrate/pre-charge phase 422, the common-mode voltage on the common voltage input 258 is reduced to  $V_{CM\_int}$  and the programming input 232 ( $V_{Data}$ ) is increased to a level 412 ( $V_{INT\_IFT}$ ) such that the drive transistor 220 will conduct in the reverse direction. If the

allocated time for this phase is long enough, the voltage at the node **244** will decline until the gate to source voltage of the drive transistor **220** reaches the threshold voltage of the drive transistor **220**. Before the end of this cycle, the signal **410** ( $\phi_4$ ) to the switch **254** goes low in order to prepare the charge-pump amplifier **250** for the read phase **424**.

The read phase **424** is initiated by decreasing the signal **412** at the programming input **232** ( $V_{Data}$ ) to  $V_{RD\_TFT}$  so as to turn the drive transistor **220** on. The charge stored on the capacitor **240** ( $C_{OLED}$ ) is now transferred to the capacitor **254** ( $C_{INT}$ ). At the end of the read phase **424**, the signal **408** ( $\phi_3$ ) to the switch **264** is set to low in order to isolate the charge-pump amplifier **250** from the drive circuit **202**. The output voltage signal **416**  $V_{out}$  from the amplifier output **256** is now a function of the threshold voltage of the drive transistor **220** given by:

$$V_{out} = -\frac{C_{oled}}{C_{int}}(V_{INT\_TFT} - V_{th})$$

FIG. **4B** is a timing diagram for the in-pixel extraction of the threshold voltage of the OLED **222** in FIG. **2** assuming that the drive transistor **220** is a p-type transistor. The extraction process is very similar to the timing of signals to the extraction circuit **200** for an n-type drive transistor in FIG. **3A**. FIG. **4B** shows voltage signals **432-446** for the select input **230**, the switches **260**, **262**, **264** and **254**, the programming data input **232**, the voltage at the node **244** and the amplifier output **256** in FIG. **2**. The extraction process includes a reset phase **450**, an integration phase **452**, a pre-charge phase **454** and a read phase **456**. The major difference in this readout cycle in comparison to the readout cycle in FIG. **4A** is the voltage levels of the signal **442** to the programming data input **232** ( $V_{Data}$ ) that are applied to the driver circuit **210** in each readout phase. For a p-type thin film transistor that may be used for the drive transistor **220**, the select signal **430** to the select input **232** is active low. The select input **232** is kept low throughout the readout process as shown in FIG. **4B**.

The readout process starts by first resetting the capacitor **240** ( $C_{OLED}$ ) in the reset phase **450**. The signal **434** ( $\phi_1$ ) to the switch **260** is set high to provide a discharge path to ground. The signal **442** to the programming input **232** ( $V_{Data}$ ) is lowered to  $V_{RST\_OLED}$  in order to turn the drive transistor **220** on.

In the integrate phase **452**, the signals **434** and **436** ( $\phi_1$ ,  $\phi_2$ ) to the switches **260** and **262** are set to off and on states respectively, to provide a charging path to the OLED **222**. The capacitor **240** ( $C_{OLED}$ ) is allowed to charge until the voltage **444** at node **244** goes beyond the threshold voltage of the OLED **222** to turn it on. Before the end of the integration phase **452**, the voltage signal **442** to the programming input **232** ( $V_{Data}$ ) is raised to  $V_{OFF}$  to turn the drive transistor **220** off.

During the pre-charge phase **454**, the accumulated charge on the capacitor **240** ( $C_{OLED}$ ) is discharged into the OLED **222** until the voltage **444** at the node **244** reaches the threshold voltage of the OLED **222**. Also, in the pre-charge phase **454**, the signals **434** and **436** ( $\phi_1$ ,  $\phi_2$ ) to the switches **260** and **262** are turned off while the signals **438** and **440** ( $\phi_3$ ,  $\phi_4$ ) to the switches **264** and **254** are set on. This provides the condition for the amplifier **250** to precharge the supply line **212** (VD) to the common mode voltage input **258** (VCM) provided at the positive input of the amplifier **250**. At the end

of the pre-charge phase, the signal **430** ( $\phi_4$ ) to the switch **254** is turned off to prepare the charge-pump amplifier **250** for the read phase **456**.

The read phase **456** is initiated by turning the drive transistor **220** on when the voltage **442** to the programming input **232** ( $V_{Data}$ ) is lowered to  $V_{RD\_OLED}$ . The charge stored on the capacitor **240** ( $C_{OLED}$ ) is now transferred to the capacitor **254** ( $C_{INT}$ ) which builds up the output voltage **446** at the output **256** of the amplifier **250** as a function of the threshold voltage of the OLED **220**.

FIG. **4C** is a signal timing diagram for the direct extraction of the threshold voltage of the drive transistor **220** in the extraction system **200** in FIG. **2** when the drive transistor **220** is a p-type transistor. FIG. **4C** shows voltage signals **462-476** for the select input **230**, the switches **260**, **262**, **264** and **254**, the programming data input **232**, the voltage at the node **244** and the output voltage **256** in FIG. **2**. The extraction process includes a pre-charge phase **480** and an integration phase **482**. However, in the timing diagram in FIG. **4C**, a dedicated final read phase **484** is illustrated which may be eliminated if the output of charge-pump amplifier **250** is sampled at the end of the integrate phase **482**.

The extraction process is initiated by simultaneous pre-charging of the drain storage capacitor **224**, the source storage capacitor **226**, the capacitor **240** ( $C_{OLED}$ ) and the capacitor **242** in FIG. **2**. For this purpose, the signals **462**, **468** and **470** to the select line input **230** and the switches **264** and **254** are activated as shown in FIG. **4C**. Throughout the readout process, the signals **404** and **406** ( $\phi_1$ ,  $\phi_2$ ) to the switches **260** and **262** are kept low. The voltage level of common mode voltage input **258** (VCM) determines the voltage on the supply line **212** and hence the voltage at the node **244**. The common mode voltage (VCM) should be low enough such that the OLED **222** does not turn on. The voltage **472** to the programming input **232** ( $V_{Data}$ ) is set to a level ( $V_{RST\_TFT}$ ) low enough to turn the transistor **220** on.

At the beginning of the integrate phase **482**, the signal **470** ( $\phi_4$ ) to the switch **254** is turned off in order to allow the charge-pump amplifier **250** to integrate the current through the drive transistor **220**. The output voltage **256** of the charge-pump amplifier **250** will incline at a constant rate which is a function of the threshold voltage of the drive transistor **220** and its gate-to-source voltage. Before the end of the integrate phase **482**, the signal **468** ( $\phi_3$ ) to the switch **264** is turned off to isolate the charge-pump amplifier **250** from the driver circuit **220**. Accordingly, the output voltage **256** of the amplifier **250** is given by:

$$V_{out} = I_{TFT} \cdot \frac{T_{int}}{C_{int}}$$

where  $I_{TFT}$  is the drain current of the drive transistor **220** which is a function of the mobility and ( $V_{CM} - V_{Data} - |V_{th}|$ ).  $T_{int}$  is the length of the integration time. In the optional read phase **484**, the signal **468** ( $\phi_3$ ) to the switch **264** is kept low to isolate the charge-pump amplifier **250** from the driver circuit **202**. The output voltage **256**, which is a function of the mobility and threshold voltage of the drive transistor **220**, may be sampled any time during the read phase **484**.

FIG. **4D** is a timing diagram for the direct reading of the OLED **222** in FIG. **2**. When the drive transistor **220** is turned on with a high enough gate-to-source voltage it may be utilized as an analog switch to access the anode terminal of the OLED **222**. In this case, the voltage at the node **244** is essentially equal to the voltage on the supply line **212** (VD).

Accordingly, the drive current through the drive transistor 220 will only be a function of the turn-on voltage of the OLED 222 and the voltage that is set on the supply line 212. The drive current may be provided by the charge-pump amplifier 250. When integrated over a certain time period, the output voltage 256 of the integrator circuit 206 is a measure of how much the OLED 222 has aged.

FIG. 4D is a timing diagram showing the signals applied to the extraction circuit 200 to extract the turn-on voltage from the OLED 222 via a direct read. FIG. 4D shows the three phases of the readout process, a pre-charge phase 486, an integrate phase 487 and a read phase 488. FIG. 4D includes a signal 489<sub>n</sub> or 489<sub>p</sub> for the select input 230 in FIG. 2, a signal 490 ( $\phi_1$ ) to the switch 260, a signal 491 ( $\phi_2$ ) for the switch 262, a signal 492 ( $\phi_3$ ) for the switch 264, a signal 493 ( $\phi_4$ ) for the switch 254, a programming voltage signal 494<sub>n</sub> or 494<sub>p</sub> for the programming data input 232 in FIG. 2, a voltage 495 of the node 244 in FIG. 2 and an output voltage signal 496 for the output 256 of the amplifier 250 in FIG. 2.

The process starts by activating the select signal corresponding to the desired row of pixels in array 102. As illustrated in FIG. 4D, the select signal 489<sub>n</sub> is active high for an n-type select transistor and active low for a p-type select transistor. A high select signal 489<sub>n</sub> is applied to the select input 230 in the case of an n-type drive transistor. A low signal 489<sub>p</sub> is applied to the select input 230 in the case of a p-type drive transistor for the drive transistor 220.

The select signal 489<sub>n</sub> or 489<sub>p</sub> will be kept active during the pre-charge and integrate cycles 486 and 487. The  $\phi_1$  and  $\phi_2$  inputs 490 and 491 are inactive in this readout method. During the pre-charge cycle, the switch signals 492  $\phi_3$  and 493  $\phi_4$  are set high in order to provide a signal path such that the parasitic capacitance 242 of the supply line ( $C_p$ ) and the voltage at the node 244 are pre-charged to the common-mode voltage ( $VCM_{OLED}$ ) provided to the non-inverting terminal of the amplifier 250. A high enough drive voltage signal 494<sub>n</sub> or 494<sub>p</sub> ( $V_{ON,nTFT}$  or  $V_{ON,pTFT}$ ) is applied to the data input 232 ( $V_{Data}$ ) to operate the drive transistor 220 as an analog switch. Consequently, the supply voltage 212 VD and the node 244 are pre-charged to the common-mode voltage ( $VCM_{OLED}$ ) to get ready for the next cycle. At the beginning of the integrate phase 487, the switch input 493  $\phi_4$  is turned off in order to allow the charge-pump module 206 to integrate the current of the OLED 222. The output voltage 496 of the charge-pump module 206 will incline at a constant rate which is a function of the turn-on voltage of the OLED 222 and the voltage 495 set on the node 244, i.e.  $VCM_{OLED}$ . Before the end of the integrate phase 487, the switch signal 492  $\phi_3$  is turned off to isolate the charge-pump module 206 from the pixel circuit 202. From this instant beyond, the output voltage is constant until the charge-pump module 206 is reset for another reading. When integrated over a certain time period, the output voltage of the integrator is given by:

$$V_{out} = I_{OLED} \frac{T_{int}}{C_{int}}$$

which is a measure of how much the OLED has aged.  $T_{int}$  in this equation is the time interval between the falling edge of the switch signal 493 ( $\phi_4$ ) to the falling edge of the switch signal 492 ( $\phi_3$ ).

Similar extraction processes of a two transistor type driver circuit such as that in FIG. 2 may be utilized to extract

non-uniformity and aging parameters such as threshold voltages and mobility of a three transistor type driver circuit as part of the data extraction system 500 as shown in FIG. 5. The data extraction system 500 includes a drive circuit 502 and a readout circuit 504. The readout circuit 504 is part of the current supply and readout circuit 120 and gathers data from a column of pixels 104 as shown in FIG. 1 and includes a charge pump circuit 506 and a switch-box circuit 508. A voltage source 510 provides the supply voltage (VDD) to the drive circuit 502. The charge-pump and switch-box circuits 506 and 508 are implemented on the top or bottom side of the array 102 such as in the voltage drive 114 and the current supply and readout circuit 120 in FIG. 1. This is achieved by either direct fabrication on the same substrate as for the array 102 or by bonding a microchip on the substrate or a flex as a hybrid solution.

The drive circuit 502 includes a drive transistor 520, an organic light emitting device 522, a drain storage capacitor 524, a source storage capacitor 526 and a select transistor 528. A select line input 530 is coupled to the gate of the select transistor 528. A programming input 532 is coupled through the select transistor 528 to the gate of the drive transistor 220. The select line input 530 is also coupled to the gate of an output transistor 534. The output transistor 534 is coupled to the source of the drive transistor 520 and a voltage monitoring output line 536. The drain of the drive transistor 520 is coupled to the supply voltage source 510 and the source of the drive transistor 520 is coupled to the OLED 522. The source storage capacitor 526 is coupled between the gate and the source of the drive transistor 520. The drain storage capacitor 524 is coupled between the gate and the drain of the drive transistor 520. The OLED 522 has a parasitic capacitance that is modeled as a capacitor 540. The monitor output voltage line 536 also has a parasitic capacitance that is modeled as a capacitor 542. The drive transistor 520 in this example is a thin film transistor that is fabricated from amorphous silicon. A voltage node 544 is the point between the source terminal of the drive transistor 520 and the OLED 522. In this example, the drive transistor 520 is an n-type transistor. The system 500 may be implemented with a p-type drive transistor in place of the drive transistor 520.

The readout circuit 504 includes the charge-pump circuit 506 and the switch-box circuit 508. The charge-pump circuit 506 includes an amplifier 550 which has a capacitor 552 ( $C_{int}$ ) in a negative feedback loop. A switch 554 (S4) is utilized to discharge the capacitor 552  $C_{int}$  during the pre-charge phase. The amplifier 550 has a negative input coupled to the capacitor 552 and the switch 554 and a positive input coupled to a common mode voltage input 558 (VCM). The amplifier 550 has an output 556 that is indicative of various extracted factors of the drive transistor 520 and OLED 522 as will be explained below.

The switch-box circuit 508 includes several switches 560, 562 and 564 to direct the current to and from the drive circuit 502. The switch 560 is used during the reset phase to provide the discharge path to ground. The switch 562 provides the supply connection during normal operation of the pixel 104 and also during the integration phase of the readout process. The switch 564 is used to isolate the charge-pump circuit 506 from the supply line voltage source 510.

In the three transistor drive circuit 502, the readout is normally performed through the monitor line 536. The readout can also be taken through the voltage supply line from the supply voltage source 510 similar to the process of timing signals in FIG. 3A-3C. Accurate timing of the input signals ( $\phi_1$ - $\phi_4$ ) to the switches 560, 562, 564 and 554, the

select input **530** and the programming voltage input **532** ( $V_{Data}$ ) is used to control the performance of the readout circuit **500**. Certain voltage levels are applied to the programming data input **532** ( $V_{Data}$ ) and the common mode voltage input **558** (VCM) during each phase of readout process.

The three transistor drive circuit **502** may be programmed differentially through the programming voltage input **532** and the monitoring output **536**. Accordingly, the reset and pre-charge phases may be merged together to form a reset/pre-charge phase and which is followed by an integrate phase and a read phase.

FIG. **6A** is a timing diagram of the signals involving the extraction of the threshold voltage and mobility of the drive transistor **520** in FIG. **5**. The timing diagram includes voltage signals **602-618** for the select input **530**, the switches **560, 562, 564** and **554**, the programming voltage input **532**, the voltage at the gate of the drive transistor **520**, the voltage at the node **544** and the output voltage **556** in FIG. **5**. The readout process in FIG. **6A** has a pre-charge phase **620**, an integrate phase **622** and a read phase **624**. The readout process initiates by simultaneous precharging of the drain capacitor **524**, the source capacitor **526**, and the parasitic capacitors **540** and **542**. For this purpose, the select line voltage **602** and the signals **608** and **610** ( $\phi_3, \phi_4$ ) to the switches **564** and **554** are activated as shown in FIG. **6A**. The signals **604** and **606** ( $\phi_1, \phi_2$ ) to the switches **560** and **562** remain low throughout the readout cycle.

The voltage level of the common mode input **558** (VCM) determines the voltage on the output monitor line **536** and hence the voltage at the node **544**. The voltage to the common mode input **558** ( $V_{CM\_TFT}$ ) should be low enough such that the OLED **522** does not turn on. In the pre-charge phase **620**, the voltage signal **612** to the programming voltage input **532** ( $V_{Data}$ ) is high enough ( $V_{RST\_TFT}$ ) to turn the drive transistor **520** on, and also low enough such that the OLED **522** always stays off.

At the beginning of the integrate phase **622**, the voltage **602** to the select input **530** is deactivated to allow a charge to be stored on the capacitor **540** ( $C_{OLED}$ ). The voltage at the node **544** will start to rise and the gate voltage of the drive transistor **520** will follow that with a ratio of the capacitance value of the source capacitor **526** over the capacitance of the source capacitor **526** and the drain capacitor **524** [ $C_{S1}/(C_{S1} + C_{S2})$ ]. The charging will complete once the difference between the gate voltage of the drive transistor **520** and the voltage at node **544** is equal to the threshold voltage of the drive transistor **520**. Before the end of the integration phase **622**, the signal **610** ( $\phi_4$ ) to the switch **554** is turned off to prepare the charge-pump amplifier **550** for the read phase **624**.

For the read phase **624**, the signal **602** to the select input **530** is activated once more. The voltage signal **612** on the programming input **532** ( $V_{RD\_TFT}$ ) is low enough to keep the drive transistor **520** off. The charge stored on the capacitor **240** ( $C_{OLED}$ ) is now transferred to the capacitor **254** ( $C_{INT}$ ) and creates an output voltage **618** proportional to the threshold voltage of the drive transistor **520**:

$$V_{out} = -\frac{C_{oled}}{C_{int}}(V_G - V_{th})$$

Before the end of the read phase **624**, the signal **608** ( $\phi_3$ ) to the switch **564** turns off to isolate the charge-pump circuit **506** from the drive circuit **502**.

FIG. **6B** is a timing diagram for the input signals for extraction of the turn-on voltage of the OLED **522** in FIG. **5**. FIG. **6B** includes voltage signals **632-650** for the select input **530**, the switches **560, 562, 564** and **554**, the programming voltage input **532**, the voltage at the gate of the drive transistor **520**, the voltage at the node **544**, the common mode voltage input **558**, and the output voltage **556** in FIG. **5**. The readout process in FIG. **6B** has a pre-charge phase **652**, an integrate phase **654** and a read phase **656**. Similar to the readout for the drive transistor **220** in FIG. **6A**, the readout process starts with simultaneous precharging of the drain capacitor **524**, the source capacitor **526**, and the parasitic capacitors **540** and **542** in the pre-charge phase **652**. For this purpose, the signal **632** to the select input **530** and the signals **638** and **640** ( $\phi_3, \phi_4$ ) to the switches **564** and **554** are activated as shown in FIG. **6B**. The signals **634** and **636** ( $\phi_1, \phi_2$ ) remain low throughout the readout cycle. The input voltage **648** ( $V_{CM\_Pre}$ ) to the common mode voltage input **258** should be high enough such that the OLED **522** is turned on. The voltage **642** ( $V_{Pre\_OLED}$ ) to the programming input **532** ( $V_{Data}$ ) is low enough to keep the drive transistor **520** off.

At the beginning of the integrate phase **654**, the signal **632** to the select input **530** is deactivated to allow a charge to be stored on the capacitor **540** ( $C_{OLED}$ ). The voltage at the node **544** will start to fall and the gate voltage of the drive transistor **520** will follow with a ratio of the capacitance value of the source capacitor **526** over the capacitance of the source capacitor **526** and the drain capacitor **524** [ $C_{S1}/(C_{S1} + C_{S2})$ ]. The discharging will complete once the voltage at node **544** reaches the ON voltage ( $V_{OLED}$ ) of the OLED **522**. Before the end of the integration phase **654**, the signal **640** ( $\phi_4$ ) to the switch **554** is turned off to prepare the charge-pump circuit **506** for the read phase **656**.

For the read phase **656**, the signal **632** to the select input **530** is activated once more. The voltage **642** on the ( $V_{RD\_OLED}$ ) programming input **532** should be low enough to keep the drive transistor **520** off. The charge stored on the capacitor **540** ( $C_{OLED}$ ) is then transferred to the capacitor **552** ( $C_{INT}$ ) creating an output voltage **650** at the amplifier output **556** proportional to the ON voltage of the OLED **522**.

$$V_{out} = -\frac{C_{oled}}{C_{int}} \cdot V_{ON,oled}$$

The signal **638** ( $\phi_3$ ) turns off before the end of the read phase **656** to isolate the charge-pump circuit **508** from the drive circuit **502**.

As shown, the monitor output transistor **534** provides a direct path for linear integration of the current for the drive transistor **520** or the OLED **522**. The readout may be carried out in a pre-charge and integrate cycle. However, FIG. **6C** shows timing diagrams for the input signals for an additional final read phase which may be eliminated if the output of charge-pump circuit **508** is sampled at the of the integrate phase. FIG. **6C** includes voltage signals **660-674** for the select input **530**, the switches **560, 562, 564** and **554**, the programming voltage input **532**, the voltage at the node **544**, and the output voltage **556** in FIG. **5**. The readout process in FIG. **6C** therefore has a pre-charge phase **676**, an integrate phase **678** and an optional read phase **680**.

The direct integration readout process of the n-type drive transistor **520** in FIG. **5** as shown in FIG. **6C** is initiated by simultaneous precharging of the drain capacitor **524**, the source capacitor **526**, and the parasitic capacitors **540** and

542. For this purpose, the signal 660 to the select input 530 and the signals 666 and 668 ( $\phi_3, \phi_4$ ) to the switches 564 and 554 are activated as shown in FIG. 6C. The signals 662 and 664 ( $\phi_1, \phi_2$ ) to the switches 560 and 562 remain low throughout the readout cycle. The voltage level of the common mode voltage input 558 (VCM) determines the voltage on the monitor output line 536 and hence the voltage at the node 544. The voltage signal ( $V_{CM\_TFT}$ ) of the common mode voltage input 558 is low enough such that the OLED 522 does not turn on. The signal 670 ( $V_{ON\_TFT}$ ) to the programming input 532 ( $V_{Data}$ ) is high enough to turn the drive transistor 520 on.

At the beginning of the integrate phase 678, the signal 668 ( $\phi_4$ ) to the switch 554 is turned off in order to allow the charge-pump amplifier 550 to integrate the current from the drive transistor 520. The output voltage 674 of the charge-pump amplifier 550 declines at a constant rate which is a function of the threshold voltage, mobility and the gate-to-source voltage of the drive transistor 520. Before the end of the integrate phase, the signal 666 ( $\phi_3$ ) to the switch 564 is turned off to isolate the charge-pump circuit 508 from the drive circuit 502. Accordingly, the output voltage is given by:

$$V_{out} = -I_{TFT} \cdot \frac{T_{int}}{C_{int}}$$

where  $I_{TFT}$  is the drain current of drive transistor 520 which is a function of the mobility and ( $V_{Data} - V_{CM} - V_{th}$ ).  $T_{int}$  is the length of the integration time. The output voltage 674, which is a function of the mobility and threshold voltage of the drive transistor 520, may be sampled any time during the read phase 680.

FIG. 6D shows a timing diagram of input signals for the direct reading of the on (threshold) voltage of the OLED 522 in FIG. 5. FIG. 6D includes voltage signals 682-696 for the select input 530, the switches 560, 562, 564 and 554, the programming voltage input 532, the voltage at the node 544, and the output voltage 556 in FIG. 5. The readout process in FIG. 6C has a pre-charge phase 697, an integrate phase 698 and an optional read phase 699.

The readout process in FIG. 6D is initiated by simultaneous precharging of the drain capacitor 524, the source capacitor 526, and the parasitic capacitors 540 and 542. For this purpose, the signal 682 to the select input 530 and the signals 688 and 690 ( $\phi_3, \phi_4$ ) to the switches 564 and 554 are activated as shown in FIG. 6D. The signals 684 and 686 ( $\phi_1, \phi_2$ ) remain low throughout the readout cycle. The voltage level of the common mode voltage input 558 (VCM) determines the voltage on the monitor output line 536 and hence the voltage at the node 544. The voltage signal ( $V_{CM\_OLED}$ ) of the common mode voltage input 558 is high enough such to turn the OLED 522 on. The signal 692 ( $V_{OFF\_TFT}$ ) of the programming input 532 ( $V_{Data}$ ) is low enough to keep the drive transistor 520 off.

At the beginning of the integrate phase 698, the signal 690 ( $\phi_4$ ) to the switch 552 is turned off in order to allow the charge-pump amplifier 550 to integrate the current from the OLED 522. The output voltage 696 of the charge-pump amplifier 550 will incline at a constant rate which is a function of the threshold voltage and the voltage across the OLED 522.

Before the end of the integrate phase 698, the signal 668 ( $\phi_3$ ) to the switch 564 is turned off to isolate the charge-pump circuit 508 from the drive circuit 502. Accordingly, the output voltage is given by:

$$V_{out} = I_{OLED} \cdot \frac{T_{int}}{C_{int}}$$

where  $I_{OLED}$  is the OLED current which is a function of ( $V_{CM} - V_{th}$ ), and  $T_{int}$  is the length of the integration time. The output voltage, which is a function of the threshold voltage of the OLED 522, may be sampled any time during the read phase 699.

The controller 112 in FIG. 1 may be conveniently implemented using one or more general purpose computer systems, microprocessors, digital signal processors, microcontrollers, application specific integrated circuits (ASIC), programmable logic devices (PLD), field programmable logic devices (FPLD), field programmable gate arrays (FPGA) and the like, programmed according to the teachings as described and illustrated herein, as will be appreciated by those skilled in the computer, software and networking arts.

In addition, two or more computing systems or devices may be substituted for any one of the controllers described herein. Accordingly, principles and advantages of distributed processing, such as redundancy, replication, and the like, also can be implemented, as desired, to increase the robustness and performance of controllers described herein. The controllers may also be implemented on a computer system or systems that extend across any network environment using any suitable interface mechanisms and communications technologies including, for example telecommunications in any suitable form (e.g., voice, modem, and the like), Public Switched Telephone Network (PSTNs), Packet Data Networks (PDNs), the Internet, intranets, a combination thereof, and the like.

The operation of the example data extraction process, will now be described with reference to the flow diagram shown in FIG. 7. The flow diagram in FIG. 7 is representative of example machine readable instructions for determining the threshold voltages and mobility of a simple driver circuit that allows maximum aperture for a pixel 104 in FIG. 1. In this example, the machine readable instructions comprise an algorithm for execution by: (a) a processor, (b) a controller, and/or (c) one or more other suitable processing device(s). The algorithm may be embodied in software stored on tangible media such as, for example, a flash memory, a CD-ROM, a floppy disk, a hard drive, a digital video (versatile) disk (DVD), or other memory devices, but persons of ordinary skill in the art will readily appreciate that the entire algorithm and/or parts thereof could alternatively be executed by a device other than a processor and/or embodied in firmware or dedicated hardware in a well known manner (e.g., it may be implemented by an application specific integrated circuit (ASIC), a programmable logic device (PLD), a field programmable logic device (FPLD), a field programmable gate array (FPGA), discrete logic, etc.). For example, any or all of the components of the extraction sequence could be implemented by software, hardware, and/or firmware. Also, some or all of the machine readable instructions represented by the flowchart of FIG. 7 may be implemented manually. Further, although the example algorithm is described with reference to the flowchart illustrated in FIG. 7, persons of ordinary skill in the art will readily appreciate that many other methods of implementing the example machine readable instructions may alternatively be used. For example, the order of execution of the blocks may be changed, and/or some of the blocks described may be changed, eliminated, or combined.

A pixel **104** under study is selected by turning the corresponding select and programming lines on (**700**). Once the pixel **104** is selected, the readout is performed in four phases. The readout process begins by first discharging the parasitic capacitance across the OLED ( $C_{oled}$ ) in the reset phase (**702**). Next, the drive transistor is turned on for a certain amount of time which allows some charge to be accumulated on the capacitance across the OLED  $C_{oled}$  (**704**). In the integrate phase, the select transistor is turned off to isolate the charge on the capacitance across the OLED  $C_{oled}$  and then the line parasitic capacitance ( $C_P$ ) is pre-charged to a known voltage level (**706**). Finally, the drive transistor is turned on again to allow the charge on the capacitance across the OLED  $C_{oled}$  to be transferred to the charge-pump amplifier output in a read phase (**708**). The amplifier's output represent a quantity which is a function of mobility and threshold voltage. The readout process is completed by deselecting the pixel to prevent interference while other pixels are being calibrated (**710**).

FIG. **8** is a flow diagram of different extraction cycles and parameter applications for pixel circuits such as the two transistor circuit in FIG. **2** and the three transistor circuit in FIG. **5**. One process is an in-pixel integration that involves charge transfer (**800**). A charge relevant to the parameter of interest is accumulated in the internal capacitance of the pixel (**802**). The charge is then transferred to the external read-out circuit such as the charge-pump or integrator to establish a proportional voltage (**804**). Another process is an off-pixel integration or direct integration (**810**). The device current is directly integrated by the external read-out circuit such as the charge-pump or integrator circuit (**812**).

In both processes, the generated voltage is post-processed to resolve the parameter of interest such as threshold voltage or mobility of the drive transistor or the turn-on voltage of the OLED (**820**). The extracted parameters may be then used for various applications (**822**). Examples of using the parameters include modifying the programming data according to the extracted parameters to compensate for pixel variations (**824**). Another example is to pre-age the panel of pixels (**826**). Another example is to evaluate the process yield of the panel of pixels after fabrication (**828**).

FIG. **9** is a block diagram and chart of the components of a data extraction system that includes a pixel circuit **900**, a switch box **902** and a readout circuit **904** that may be a charge pump/integrator. The building components (**910**) of the pixel circuit **900** include an emission device such as an OLED, a drive device such as a drive transistor, a storage device such as a capacitor and access switches such as a select switch. The building components **912** of the switch box **902** include a set of electronic switches that may be

controlled by external control signals. The building components **914** of the readout circuit **904** include an amplifier, a capacitor and a reset switch.

The parameters of interest may be stored as represented by the box **920**. The parameters of interest in this example may include the threshold voltage of the drive transistor, the mobility of the drive transistor and the turn-on voltage of the OLED. The functions of the switch box **902** are represented by the box **922**. The functions include steering current in and out of the pixel circuit **900**, providing a discharge path between the pixel circuit **900** and the charge-pump of the readout circuit **904** and isolating the charge-pump of the readout circuit **904** from the pixel circuit **900**. The functions of the readout circuit **904** are represented by the box **924**. One function includes transferring a charge from the internal capacitance of the pixel circuit **900** to the capacitor of the readout circuit **904** to generate a voltage proportional to that charge in the case of in-pixel integration as in steps **800-804** in FIG. **8**. Another function includes integrating the current of the drive transistor or the OLED of the pixel circuit **900** over a certain time in order to generate a voltage proportional to the current as in steps **810-814** of FIG. **8**.

While particular embodiments and applications of the present invention have been illustrated and described, it is to be understood that the invention is not limited to the precise construction and compositions disclosed herein and that various modifications, changes, and variations can be apparent from the foregoing descriptions without departing from the spirit and scope of the invention as defined in the appended claims.

What is claimed is:

**1.** A method of extracting mobility from a drive transistor in a pixel circuit based on the transient settling of the drive transistor, said method comprising:

measuring the current of the drive transistor over a constant interval; and  
calculating the mobility of the drive transistor from the measured current.

**2.** The method of claim **1** in which a threshold voltage of the drive transistor is compensated prior to mobility measurement.

**3.** The method of claim **1** in which the measurement of the current comprises:

a) converting the current into voltage by integration; and  
b) sampling the output voltage at a constant interval after the beginning of said integration.

**4.** The method of claim **1** in which the current is measured at a plurality of different timing intervals and mobility is extracted from the sampled currents.

\* \* \* \* \*

专利名称(译)	用于在AMOLED显示器中提取阈值和移动性参数的系统和方法		
公开(公告)号	<a href="#">US9589490</a>	公开(公告)日	2017-03-07
申请号	US15/154445	申请日	2016-05-13
[标]申请(专利权)人(译)	伊格尼斯创新公司		
申请(专利权)人(译)	IGNIS创新INC.		
当前申请(专利权)人(译)	IGNIS创新INC.		
[标]发明人	CHAJI GHOLAMREZA AZIZI YASER		
发明人	CHAJI, GHOLAMREZA AZIZI, YASER		
IPC分类号	G09G3/00 G09G3/32 G01R19/00		
CPC分类号	G09G3/006 G01R19/0092 G09G3/3233 G09G3/3258 G09G3/3291 G09G2300/043 G09G2300/0819 G09G2300/0842 G09G2300/0866 G09G2310/0251 G09G2320/029 G09G2320/0233 G09G2320/0295 G09G2320/043 G09G2320/045 G09G2330/028 G09G3/3266 G09G2300/0465 G09G2310/0291 G09G2310/08 H03F3/2171		
代理机构(译)	尼克松皮博迪律师事务所		
审查员(译)	LEE , NICHOLAS		
优先权	13/950795 2015-07-28 US 13/112468 2013-11-05 US		
其他公开文献	US20160253937A1		
外部链接	<a href="#">Espacenet</a> <a href="#">USPTO</a>		

摘要(译)

一种改善AMOLED显示器中晶体管参数提取的系统，包括具有有机发光器件的像素电路，向发光器件提供可编程驱动电流的驱动器件，提供编程信号的编程输入，以及存储编程信号的存储设备。电荷泵放大器具有电流输入和电压输出。电荷泵放大器包括负反馈配置的运算放大器。反馈由连接在输出和运算放大器的反相输入之间的电容器提供。共模电压源驱动运算放大器的非反相输入。电子开关耦合在电容器两端以复位电容器。包括输入的开关模块耦合到像素电路的输出，并且输出耦合到电荷泵放大器的输入。

